

CLYDESDALE

Bargains in Ex-Services Radio and Electronic Equipment

Brand New
QRO POWER SUPPLY FOR P.A. AND MODULATOR

In maker's wood case

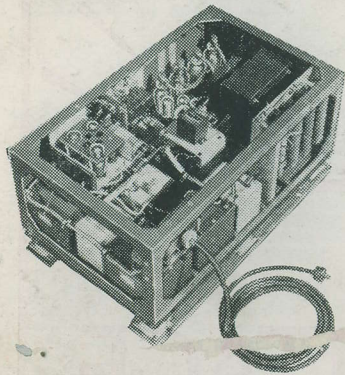

EX-CANADIAN ARMY SUPPLY UNIT RECTIFIER
This power pack was originally intended for use with the No. 43 Transmitter. It has an AC input of 110 V, 50/60 cycles 1.7 KVA. The outputs include:—2,100V. H.T. at 375 M/a., 500V. H.T. at 400 M/a., 385V. Regulated, 450V. H.T. line, 275V. H.T. line, plus 415V. Neg. bias, 250V. Neg. bias, 150V. Neg. bias, and 80V. Neg. bias.

The Unit features 3 complete power supplies, one of which provides various Low H.T. voltages. All smoothing circuits are of dual choke with condenser inputs.

Rectification on the Hi V. side is carried out by 4/866—866A Mercury vapour rectifiers, Lower H.T. circuits employ a 5Z3, with 2/6A3's and a VR150/30 for stabilisation. A IV. thermal delay starter tube is also fitted in the M.V. rectifier circuits.

Various transformers are employed namely:—2,100—500—0—500—2,100, 450—0—450—13V. CT—6.3V. CT—and 6.3V. Fil. Trans.—2.5V. CT twice and a 6.3V. transformer to operate the IV. thermal starter. 2/15H. 375 M/a. chokes plus a 15H. 400 M/a., 2/15H., 110 M/a. and a 20H. 162 M/a. A number of associated H.V. working condensers and H.D. bleeders are also included.

The complete unit is built into a metal case with lid 30 x 18 x 12 ins. finished in drab olive crackle and fitted with rubber absorber feet. Weight 420 lbs.

CLYDESDALE'S PRICE ONLY

£16 each CARRIAGE PAID

THE '144' MERCHANT

By STRATTON, the P.40 Receiver. This set covers a frequency of 85—95 Mc/s. in its present form, with a crystal controlled oscillator stage, providing facilities for tuning the receiver to a spot channel between 3.15 and 3.53 Metres. Modifications for use on '144' should not prove too hazardous!

The receiver employs a 2.9 Mc/s. I.F., and a valve line up of 1/VR136 EF54 (RF), VR136 EF54 (mixer), VR137 EC52—VR136 EF54—VR136 EF54 (oscillator and multiplier stage), 2/VR53 EF39 (IF), VR54 EB34 (det. and AVC), 6J5 (1st. audio), 6V6 (output).

Enclosed in a die-cast frame with louvred cover. Dim. 11½ x 5½ x 4½ in.

CLYDESDALE'S PRICE ONLY

£3 19s. 6d. each CARRIAGE PAID

FOR MARINE USE

The CRV 46151 is a 6 valve superhet suitable for shipping, with a frequency coverage of 195—9050 kc/s. 1 R.F., and 3 I.F. stages, plus an audio output stage. The 3rd IF stage provides CW Osc.

VALVE LINE UP—4/12SF7, 1/12SA7, 1/12A6 and 1/991 stabilizer.

H.T. power is derived from a 28V dynamotor mounted sub-chassis, which has an output of 260V/70 Ma. The valves are wired in series/parallel providing a 24V heater circuit.

Complete in metal case 15½ x 8 x 7½ in. Weight 26.8 lbs.

CLYDESDALE'S PRICE ONLY

£5 19s. 6d. each CARRIAGE PAID

SNAG! A 12 VOLT HEATER CIRCUIT

Not any more! This extremely compact A.C. Mains Power Unit has an L.T. output of 12.5V. at 2.5A. together with an H.T. supply of 175V. at 60 m/a. The A.C. input is 0—200/250 50/60 cycles.

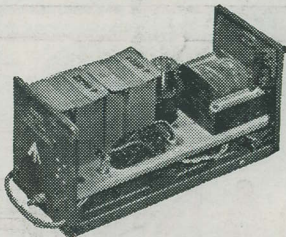

Dual choke smoothing with condenser input, 5Z4 rectification, pilot lamp, and on/off sw.

Totally enclosed in a louvred metal cabinet 11½ x 5½ x 4½ ins. finished in grey.

CLYDESDALE'S PRICE ONLY

39/6 each POST PAID

STILL AVAILABLE

The R.1224A, 5 valve battery powered receiver with real communications features. An extremely sensitive set, tuning "SHIPPING", "TOP BAND", 160M., "80", and 40 Metres. This superhet is REALLY FB.

CLYDESDALE'S PRICE ONLY

£5 19s. 6d. each POST PAID

YOUR FULL POWER LICENSE

The Power Unit 247 will provide you with enough volts/current for a 120 Watt final, and if a pair of justifiably famous 807's (our price 10/6 each) are used in the Final you have the heater supply laid on, for the '247' will provide you with 600 volts D.C. H.T. at 200 M/a. and 6.3 volts at 3 amps L.T., and it is worth remembering that the Modulator can be powered by one of these units. The '247' employs a 580—0—580 v/200 M/a., 6.3v/3 amps transformer with an 0—230v AC primary, condenser input, single choke filter, 5U4 rectifier, and pilot lamp. Enclosed in a louvred metal case finished in grey with chrome carrying handles. 11 x 9½ x 7½ ins.

The '247' is an extremely compact "Power Egg".

CLYDESDALE'S PRICE ONLY

£2 19s. 6d. each
CARRIAGE PAID

PORTABLE OR SHIPBOURNE

The Jefferson-Travis Vibropack type UFI will provide you with the VA. Input 12 volts. Output H.T. 120—150 volts at 30/40 m/a. Choke capacity smoothed, also Grid Bias and L.T. outputs.

Synchronous vibrator, complete in self contained black crackle box 7 x 6 x 4 ins., with 4½ ft. of cable and croc clips for accumulator connections.

CLYDESDALE'S PRICE ONLY

19/6 each
POST PAID

ORDER DIRECT FROM:

CLYDESDALE SUPPLY CO., LTD.

VISIT OUR BRANCHES IN SCOTLAND, ENGLAND AND NORTHERN IRELAND.

'Phone: SOUTH 2706/9

2 BRIDGE STREET
GLASGOW - C.5.

Published by Amalgamated Short Wave Press Ltd. 57 Maida Vale, Paddington, London W.9 and Printed by A. Quick and Co. Ltd. Jackson Road, Clacton-on-Sea.

Vol. 4
Number 4
NOVEMBER
1950

RADIO CONSTRUCTOR

for the Radio and Television Enthusiast

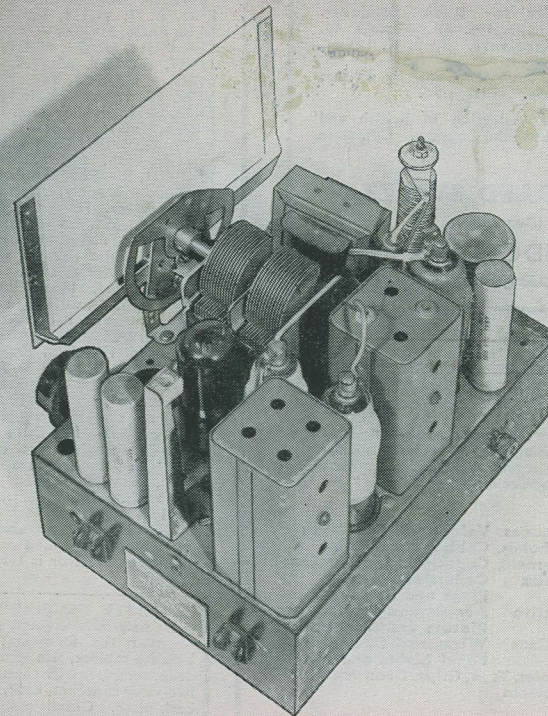

IN THIS ISSUE... CONVERTING THE TR1196 RECEIVER
Overcoming that Mains Drop • Modifying the 18 Receiver
Easily Added "S" Meter • Cathode Follower Output Stage
Simple Radiogram • Aerials, TV Picture Faults, Mailbag

etc., etc.

13

THE MODERN BOOK CO.

Testing Radio Sets. By J. H. Reyner. 22s. 6d. Postage 9d.
The Radio Amateur's Handbook, 1950 Edition. By A. R. R. L. 20s. Postage 9d.
Sound Reproduction. By G. A. Briggs. 10s. 6d. Postage 6d.
Television Servicing. By Heller & Shulman. 47s. Postage 9d.
Recent Advances in Radio Receivers. By L. A. Moxon. 18s. Postage 6d.
Radio Valve Data—compiled by "Wireless World." 3s. 6d. Postage 3d.
Radio Servicing Equipment. By E. J. G. Lewis. 25s. Postage 9d.
The Amplification and Distribution of Sound. By A. E. Greenlees. 16s. Postage 6d.
Television Explained. By W. E. Miller. 5s. Postage 4d.
Basic Mathematics for Radio Students. By F. M. Colebrook. 10s. 6d. Postage 4d.
Amateur Radio Receivers. By S. K. Lewer. 3s. 6d. Postage 2d.
Radio Handbook, 12th Edition. By Editors and Engineers. 25s. Postage 9d.

We have the finest selection of British and American radio books in the Country. Complete list on application.

19 - 23 PRAED STREET

(Dept. RC)

LONDON W.2

PADDington 4185

Come to **SMITH'S** of **EDGWARE ROAD** the friendly shop for all radio components

We stock everything the constructor needs—our 25 years experience of handling radio parts and accessories enables us to select the best of the regular lines and the more useful items from the surplus market in:—

Loudspeakers and Phones	Valves and CR Tubes
Transformers and Chokes	Cabinets and Cases
Meters & Test Equipment	Capacitors and Resistors
Pickups and Turntables	Coils and Formers
Switches and Dials	Plugs and Sockets
Metalwork and Bakelite	Aerials and Insulators
Books and Tools	Motors and Generators
Valve Holders and Cans	Wires and Cables
Metal Rectifiers	Panel Lights and Fuses
Sleeving, Nuts and Bolts, Tags, Clips, Grommets and all other bits and pieces	

NOTHING TOO LARGE—NOTHING TOO SMALL

Everything you need under one roof—including all the parts specified for the popular "Viewmaster" Home-built Television, both London and Birmingham models. Send for list of our "Electro-Voice" range of Transformers and Chokes—"As good as the best, yet cost little more than the cheapest!" (No general catalogue available).

H. L. SMITH & CO. LTD.
 287/9 Edgware Road, London, W.2

Telephone: Paddington 5891
 Hours 9 till 6 (Thursday, 1 o'clock)
 Near Edgware Road Stations, Metropolitan and Bakerloo

HENRY'S

TYPE 21 RECEIVERS. 2-band, 4.2 to 7.5 and 19 to 31 mc/s, contains 11 valves, ARPI21VP23 (7), AR8/HL23DD (4), 3 I.F. stages, 3-gang and 2-gang variable condensers in tandem to give separate R.F. sections for each waveband, slow motion drive and dial, volume, on/off and wave-change, etc. controls, chassis mounted with side protection frame, $9\frac{1}{2} \times 8\frac{1}{2} \times 6\frac{1}{2}$ in. Absolutely brand new at 45/-, carriage paid. Circuit supplied.

21 RECEIVER VIBRATOR PACK. Brand new, complete, at 17/6, carriage free.
FREQUENCY CONTROL CRYSTALS. By American G.E. Co. Octal base fixing. Following frequencies only: 2,500 k/cs, 3,500 k/cs, 4,600 k/cs, 6,200 k/cs, 8,000 k/cs, at 7/6 each only. **NEW CONDITION.**

EX-GOVT. VALVES. The following brand new and guaranteed valves are in stock:—6J6 at 12/6, 6AK5 at 10/6, 6F7, PEN46, 6L6 metal, at 10/- each. 25A6G, 6SN7GT, EF50, EF54, 25A6G, EF55, RL37, VU111, VU133, U18, 5T4, 5R4GY, RL18, 6AG5, PM22A, VU120A, 6K6 all at 7/6 each. 5Z4, MU14, 6K7GT, 6J7GT, 6K8GT, ML4, I2SR7, I2SK7, 6SA7GT, 6SL7GT, 6S17, 6SC7GT, 6C6, 6V6G or GT, 7C7, 7T4, 7B6, 7C5, I299A, 9D2, VP23, P2, 12A6, 8D2, 15D2, EF36, EF39, EBC33, EK32, EL32, 6X5GT, 2X2, 6AC7, 6N7, 78, 9003, IN5GT, 6J5GT, 6C5, KTW61, DH63, 955, TDD2A, VB2B, AC/6PEN, 220SG, 210DET, EF8, KT2, U22, all at 6/6 each. Also 9002 and 1LN5GT, 8/6; 807, 7/-, 4D1, 5/-, EA50, SP61, 954, EB34, at 3/6 each. DI Diode at 2/3 only. And the midrange of 1.4v battery valves. IT4 and IS5, at 6/6 each. IR5 and IS4, at 7/6. 3S4, at 9/- each. Most of these valves are boxed. Please note for current popular circuits we also have in stock ID8GT, at 15/3; and HIVAC XH at 10/6. Both these latter are new and boxed. In addition we have over 10,000 new boxed BVA valves in stock at current Board of Trade prices. Let us have your enquiries.

VERY SPECIAL. Standard Telephones H4/200 EHT pencil rectifiers, brand new, 2,400v 3m/a. only 15/- each. **ALSO**—The very latest slider pots, as used in all the latest T/V receivers. Bank of 4, comprising 2 of 10 K, 1 each 100 ohm, 500 ohm. Only 6/- complete. Not repeatable.
No. 18 SET RECEIVER PORTION. A four-wave superhet receiver operating from 6.9 Mc/s (33m-50m). Valve line-up: 3 ARPI2 (VP23), and AR8 (HL23DD). Requires only 120v H.T., 9v G.B. and 2v L.T., in perfect condition, only 17/6, plus 1/6 packing and carriage. An absolute bargain. Suitable brand new headphones can be supplied at 3/6 per pair.
N.B.—Each receiver is tested working, prior to despatch.

BAKELITE RECEIVER CABINETS. An extremely advantageous purchase, enables us to offer the following:—Attractive brown bakelite cabinet, size 15in. x 8 $\frac{1}{2}$ in. high x 7 $\frac{1}{2}$ in. deep, complete with chassis drilled for standard five-valve superhet, back, 3-wave glass dial and back plate. Chassis and cabinet are designed for 6 $\frac{1}{2}$ in. speaker, and all standard components. Price complete is 25/- only. Limited quantity.

SPECIAL VALUE IN MAINS TRANSFORMERS. Parmeko 250-0-250, 90 m/a 6.3v, 3a, 5v. 2a, half shrouded, drop through type. Electrostatic screen. Price 15/- only, plus 9d. post. Limited quantity.
MIDGET .0005 mfd. TWO-GANG TUNING CONDENSER. Size only 2 $\frac{1}{2}$ in. x 1 $\frac{1}{2}$ in. x 1 $\frac{1}{2}$ in. Capacity guaranteed, standard length $\frac{1}{2}$ in. spindle, complete with mounting bracket, less trimmers, 6/6, or complete with "built-in" trimmers, 7/6. Each plus 6d. post.

5 HARROW ROAD W.2

(Opposite Edgware Road Tube)
 PADDington 1008/9 & 4041



Radio Constructor

Vol. 4, No. 4

Annual Subscription 16/-

November, 1950

Editorial Office—57, Maida Vale, Paddington, London, W.9.

Tel.: CUNningham 6518

Advertising—Radio Constructor, 15, Charterhouse St., London, E.C.1. Tel.: HOLborn 8655

Edited by: C. W. C. OVERLAND, G2ATV

CONTENTS

A Constructor Looks at The Radio Show. Report by W. Groome - - -	110
Converting The TR1196 Receiver, by J. Simmons - - -	112
RSGB Amateur Radio Exhibition Overcoming That Mains Drop, by J. R. Davies - - -	116
EHT for 7/6—Further Notes - - -	119
Radio Miscellany, by Centre Tap Practical Aerials, Pt. 3, by Aetherium - - -	121
Television Picture Faults, Pt. 8, The CR Tube - - -	122
Query Corner - - -	124
An Easily Added "S" Meter, by Centre Tap - - -	130
A Cathode Follower Output Stage, by D. W. Drakeley - - -	135
A Simple Radiogram, by W. E. Crees - - -	138
Building Your Own Signal Generator—A New Attenuator, by W. G. Morley - - -	140
Your Workshop - - -	144
From Our Mailbag - - -	144
Panel Sheet No. 5—Danger, High Voltage - - -	145

Editorial

Interference

LAST month, we recorded that Birmingham had set a good example by fitting all municipal vehicles with interference suppressors. Now we hear that, in future, the Nuffield Organisation will be fitting suppressors to all Morris, Wolseley, Riley and MG vehicles. Already GPO, Police, London Transport, British Railways, BBC, Ministry of Civil Aviation, and British Electricity Authority vehicles are so equipped. Further, two advisory committees have been set up by the Postmaster-General to deal with the problem of interference from cars and refrigerators. All this makes good reading, but there still remains the problem of existing electrical machinery, particularly such items as electric razors, vacuum cleaners, hair dryers and so forth. Dare we hope that all our readers who possess likely sources of interference have fitted the required suppressors?

The Show

Short Wave Enthusiasts this month have the opportunity of attending their own exhibition. Organised by the Radio Society of Great Britain, it will be held as usual at the Royal Hotel, Woburn Place, London, W.C.1. Further particulars appear in this issue on page 116. We ourselves will be at Stand 4, and cordially invite you to visit us there.

G2ATV

NOTICES

THE CONTENTS of this magazine are strictly copyright and may not be reproduced without obtaining prior permission from the Editor. Opinions expressed by contributors are not necessarily those of the Editor or proprietors.

THE EDITOR invites original contributions on construction of radio subjects. All material used will be paid for. Articles should be clearly written, preferably typewritten, and photographs should be clear and sharp. Diagrams need not be large or perfectly drawn, as our draughtsmen will redraw in most cases, but relevant information should be included. All Mss must be accompanied by a stamped addressed envelope for reply or

return. Each item must bear the sender's name and address.

COMPONENT REVIEW. Manufacturers, publishers, etc., are invited to submit samples or information of new products for review in this section.

ALL CORRESPONDENCE should be addressed to Radio Constructor, 57, Maida Vale, Paddington, London, W.9. Telephone: CUN. 6518.

A CONSTRUCTOR looks at THE RADIO SHOW

Report by W. Groome.

OUR Editor has decided (wisely, I think) that the usual stand-by-stand report of the Radio Show would not be of much service to readers of 'RC' and, frankly, the writer is delighted to be spared the dull job of compiling such a catalogue.

A few brickbats have to be hurled, but let us first present a large and fragrant bouquet—to the BBC Television Service, or rather to those members of it who put Castle Bromwich on the screen.

I was at the exhibition in time to see the rehearsal of the opening ceremony. The actual transmission showed the arrival of the Lord Mayor of Birmingham, and he was kept on the screen as he traversed the considerable distance through the gangways to the studio, the camera 'retreating' ahead of him throughout and the many yards of cables being deftly taken back as it became spare.

It has been said that prior to a transmission a TV studio becomes a scene of chaos and noise. This was not evident here—in fact, when the writer took his seat a few minutes before the opening broadcast he was most impressed by the quiet efficiency of the preparations.

The general public was able to see this and other broadcasts through windows on two sides of the studio. Also visible to the public were the studio of the Radio Industry Council, its control room, and equipment for the internal TV and Sound distribution.

Television was the high spot of the show, and the idea of a communal exhibit of televisions was excellent, for it enabled one to make comparisons between the performances of various makes. Many were excellent, but a few had faults which are apparent to the eye of any man who has built and adjusted his own gear, though they might not, perhaps, irritate the average purchaser. They were, possibly, errors in adjustment; one set, for instance, showed frame flyback during blank screen periods.

The writer likes the new masking technique, which utilises almost the full width of the tube and gives a picture with round sides. The loss of the corners is more than compensated by he increased size of objects on the screen,

and the greater scan makes for better definition with a given spot size.

Projection TV is now well established, and the large picture is most impressive. The brightness is not so great as one sees on direct-view screens and, at any rate as far as I am concerned, there seemed to be a reduction of sharpness. Perhaps the screen is responsible for some coarsening, or is it that it has not been possible to reduce the particle size of the fluorescent material to the same degree as the tube diameter? The system is not designed for such close viewing as it received at the Show, but one feels that where large viewing groups are involved and suitable spacing is provided, optical projection gives the answer. Close-up shots seem to be almost life size. Despite the above remarks about brightness, it must be emphasised that there was sufficient light on the screen to give an easily visible picture where the room lighting approximated to that likely to be used in the home.

The use of a fair amount of soft lighting enabled viewers to judge the sets under "home" conditions, and it is quite evident that "black-out" viewing is not necessary, even with the cheapest sets.

What of the poor old Amateur? Sadly neglected, unfortunately. In view of the fact that many thousands of televisions and vast numbers of broadcast receivers are constructed by Amateurs, the writer hoped to see some displays of components. But the people who make the coil assemblies, scanning equipment, transformers, chokes and all the other gear used by the constructor were not very conspicuous.

When one realises that the support of the home builder justifies the existence of several esteemed monthly publications and many published TV and radio designs, it is clear that manufacturers are missing good opportunities by failing to appear, and the Amateur leaves the exhibition disappointed. He is a buyer of a different type to the average person. He will purchase good and useful components, but has only a passing interest in the shiny, finished sets.

The writer suggests that manufacturers should consider the Radio Show as an oppor-

tunity of encouraging the amateur movement, and to make a better appearance next year. Could not some form of joint exhibit of components be arranged?

(Our readers will be better catered for at the Amateur Radio Exhibition being held this month. Details appear elsewhere in this issue.—Ed.)

The RAF exhibit emphasised the very great influence of radio and radar in current defence measures, and the demonstrations with scale models made Stand 19 a point of great interest.

The G.P.O. in one of its displays showed, in a manner understandable to the non-technical, the effects of ignition interference on TV and the simplicity of effective suppression. It also explained how essential a good aerial is, even these days, if the best reception is to be obtained. The writer has always been amazed to hear people complaining of background noise, when often the so-called aerial is a few feet of wire at ground level. The G.P.O. renders good service in attempting to educate the public on these matters.

In outside broadcasts of TV, the G.P.O. now use the ordinary telephone system to convey the signal for several miles, if necessary, to the nearest point in the co-ax network. The apparatus used to maintain the high frequencies, which would otherwise be lost completely, was on view. It was difficult to detect any fault in a picture which reached the screen after travelling through two half-mile drums of ordinary telephone cable. By switching the network, it was shown how vast is the difference between the compensated signal and that which crawls through, horribly mutilated, without compensation.

A two-way intercommunication set by Trix is offered for domestic use, particularly as a baby alarm. Any proud father who has £13 17s. 6d. left after paying the nursing home fees may care to invest, but the writer's baby has sufficient acoustic output to make this use of the set unnecessary! Seriously, one can appreciate that this type of set has many uses such as, for example, in cases of illness.

Long playing micro-groove records have brought out a number of 33 1/3 rpm motors and record players. Some are arranged to run at three speeds, i.e., 78, 33 1/3 and 45 rpm, the latter because of the possibility of certain American discs reaching this happy land. Let us hope that British record manufacturers will standardise one LP speed—obviously 33 1/3 revs. since they are already in production.

Broadcast sets are little changed, except that cabinets seem to be better. Plastic cabinets are not so evident as was expected and the trend towards the more pleasant wood case is to be commended. The per-

sistence of the "four or five plus rectifier" type of receiver is, of course, entirely due to public demand for modesty in price. Genuine high-fidelity jobs, such as the "Decola", are very expensive, and so "hi-fi" is still available only to the "well-off"—or the amateur constructor.

To conclude these notes, mention must be made of an exhibit which may have appeared strange to younger visitors, but was probably recognised by anyone who was old enough to twist a reaction knob in 1927. This was a Cossor "Melody Maker", and its presence at the exhibition with its 1950 namesake not only stirred up childhood memories, but also emphasised the enormous strides which have taken place in the development of radio in less than 25 years.

Trade Review

NEW RADIO AND TELEVISION Trimming Kit

A unique aid in the trimming and alignment of radio and television sets is the Newman Master Set Trimmer Kit introduced by J. and S. Newman Ltd., of 100, Hampstead Road, N.W.1. This kit, measuring 4ins. × 4ins. × 1in. deep is pocket size and fitted with

- 1 End Trimmer
- 1 Side Trimmer
- 1 Yaxley Switch Contact Adjuster
- 1 Low Capacity Trimmer
- 1 Screwdriver
- 1 Set of Feeler Gauges
- 1 Set of six Box Spanners from 1 to 8 B.A.
- 1 Set of four Spanners from 0 to 8 B.A.

The metal case has a durable black crackle finish. Price 25/6 post free.

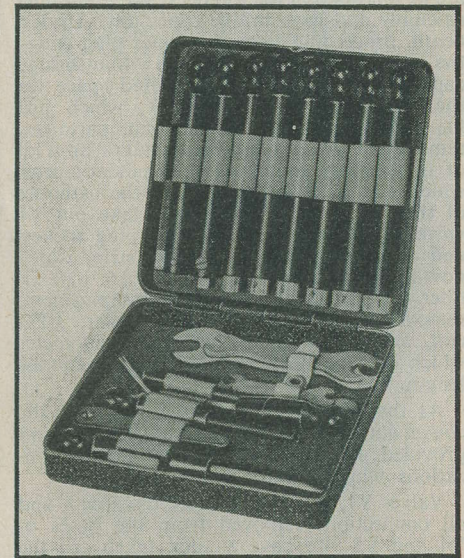

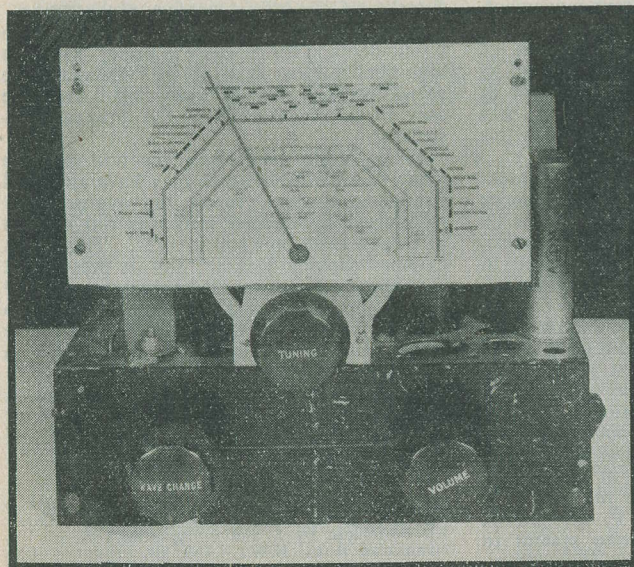

CONVERTING THE TR1196 RECEIVER

by

J. Simmons

of the Radio and
Electrical Mart

THE receiver portion of the TR1196 lends itself to easy conversion to an all-wave, mains operated receiver, and in the accompanying article details for this are given, with photographic illustrations.

First, it is necessary to remove certain components which are not required. These are as follows: On the top deck, the pre-tuning assembly and Mansbridge capacitor. Underneath, proceeding from the Jones plug end—the phone transformer and Mansbridge capacitors (this gives the required space for the Osmor all-wave coil pack, which just fits nicely here). In the next compartment, remove the Jones plug, which takes up a lot of unnecessary room, and the potentiometer which was used for controlling the cathodes of the VR57 and VR53. Also take out V1 valve base (nearest the bakelite plug socket) and the latter with its bakelite strip, which now leaves a useful space for the 16 + 16 μ F filter capacitor. In the main compartment, remove the microphone transformer, BFO coil, and the volume control potentiometer which is of no use owing to its short spindle length.

As the Osmor coil pack was used for the conversion, the writer decided to use the circuit provided with the pack, with certain modifications which will be explained later.

Valves V1, V4 and V5 were discarded, and all connections removed from the bases of V4 and V5—we have already taken out the

holder of V1. V6, the DDT (VR55) was replaced in the socket of V4, and rewired accordingly. The original V6 holder was used for the 6V6 output valve—see cover photo. Next check the resistors and capacitors on the tag strips against those required, and remove any not wanted.

At this stage, the IF transformers need a little attention. It will be seen that the first IFT has two leads coming from the top of the can. Only one of these is wanted, so remove the can and snip off that lead which is joined to C21 (100 pF) and R19 (500 k Ω) on the top right looking at the trimmers. C21 and R19 may also be removed, if desired.

Now have a look at the bottom coil—a 200 Ω resistor will be noted which has a lead from each side going out through the base plate. The writer is not quite clear as to why this was used, as it is not shown in the original circuit. However, remove the right-hand lead, still looking at the trimmers, and short the resistor by soldering a piece of wire across it. This now gives us the four leads which we need, which should be left wired as shown in the TR1196 circuit, except for the connection from V3 grid to C21.

Next we deal with IFT2 (T3 in circuit). Here again, remove the can cover and, looking at the trimmers, it will be seen that the bottom coil here also has the 200 Ω resistor with the extra lead. This resistor is dealt with in the same way as in IFT1 (T2). The top half of

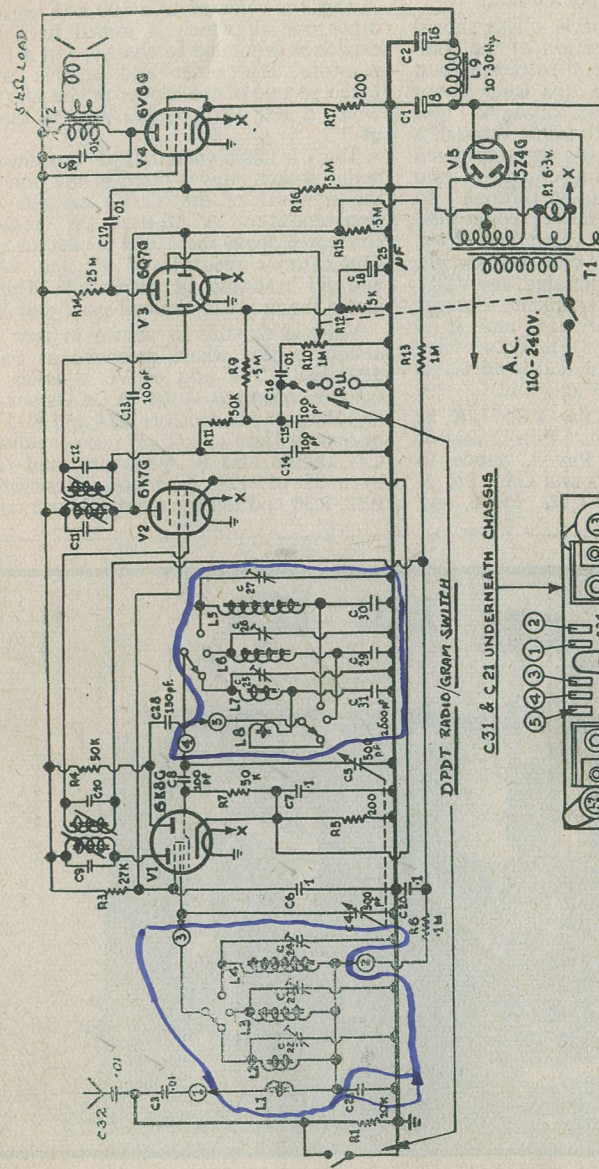

Handwritten notes:
 Vackay 22/6 + 2/6
 Ch. Britain 20/- no
 H.P. 21/- + 1/6
 UEI 22/6 + 2/6
 C99

Handwritten note:
 6V6

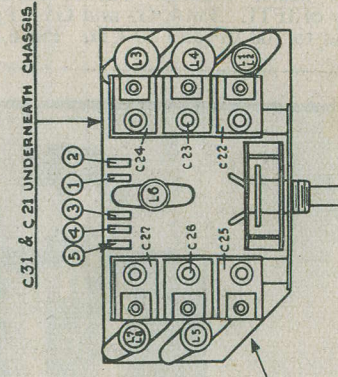

Caption for chassis diagram:
 C30 & C59 UNDERNEATH CHASSIS

Handwritten note:
 K2-0-4.

The Osmor Circuit referred to in the text.

the IFT is normal and should not be interfered with. Only one lead has to be rewired; that is the return half of the secondary going to the volume control, which should be connected as shown in the Osmor circuit.

Now return to the coil pack. This should be placed in the central portion of the compartment, as shown in the illustration, but, before doing so, solder on five leads about 10 ins. long, and an extra lead to Tag 4. Two leads from Tags 3 and 4 are taken through a hole in the deck of the chassis to be soldered to the 2-gang 500 pF tuning capacitor, and the other three leads are passed through into the Jones plug compartment for connection to the frequency changer valve and AVC line as shown in the Osmor coil pack circuit. For the benefit of the uninitiated, the VR57 is a Mullard EK32 octode frequency changer with variable-mu characteristics, and it is essential that the SG (pins 3, 5) should not have more than 80V applied, so that it is advisable to leave it wired to R8, R9 and C12.

The pin connections of the VR57 are as follows:— Pin 1, to chassis. Pins 2 and 7, to 6.3V heater winding. Pin 3, anode to primary of IFT1. Pin 4, G3 and G5. Pin 5, osc. grid to 100 pF and 50 kΩ. Pin 6, osc.

anode to 150 pF, 50 kΩ and via capacitor to Tag 5. Top Cap, control grid taken to that section of the tuning capacitor to which the lead from Tag 3 has already been connected.

Tag 2 is soldered to a 100 kΩ resistor, the other end of which is joined to a 0.1 μF capacitor grounded to chassis, and a 1 Meg Ω resistor. The other end of this latter is taken to one of the diodes of the DDT, from which a 100 pF capacitor goes to the anode of V3.

Tag 1 is taken via a 0.01 μF capacitor to the aerial socket—this is fitted in the hole left by the removal of the V2/V3 cathode control potentiometer. A 10 kΩ ½W resistor is connected from the aerial socket to ground. The cathode resistors of V2 and V3 (R10 and R17) should be grounded. This completes the mods to the coil pack and V2.

Valve 3 remains as shown in the TR1196 circuit, except where amended as has been described. The grid of V6 is taken to the volume control as shown in the Osmor circuit, and the cathode resistors R34 and R35 should be removed and a 3 kΩ ½W resistor substituted. C37 should also be taken out, and replaced by a 25 μF 12V capacitor. Resistors R33, R32, R30 and the capacitor C34 are removed.

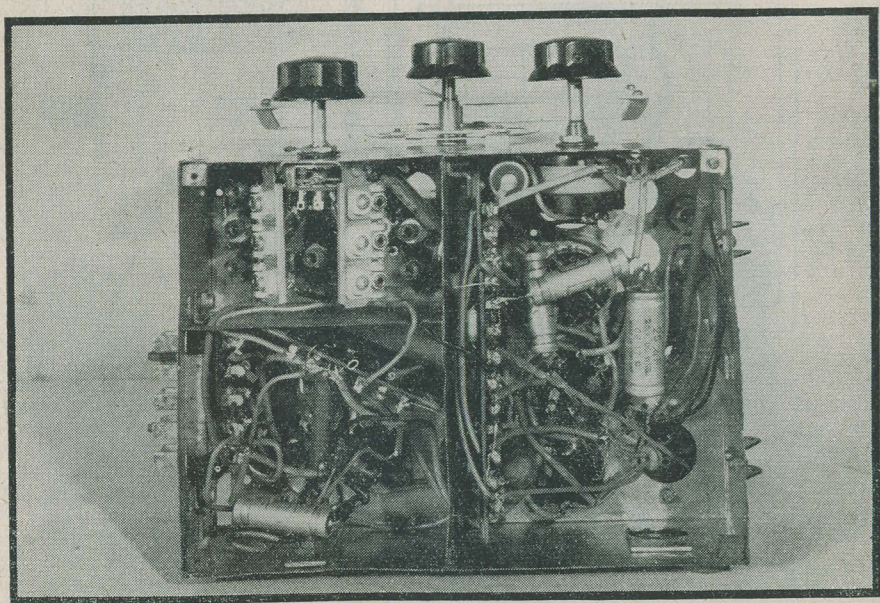

Underneath view of the modified receiver. A three-quarter rear view showing layout above deck is shown in the cover illustration.

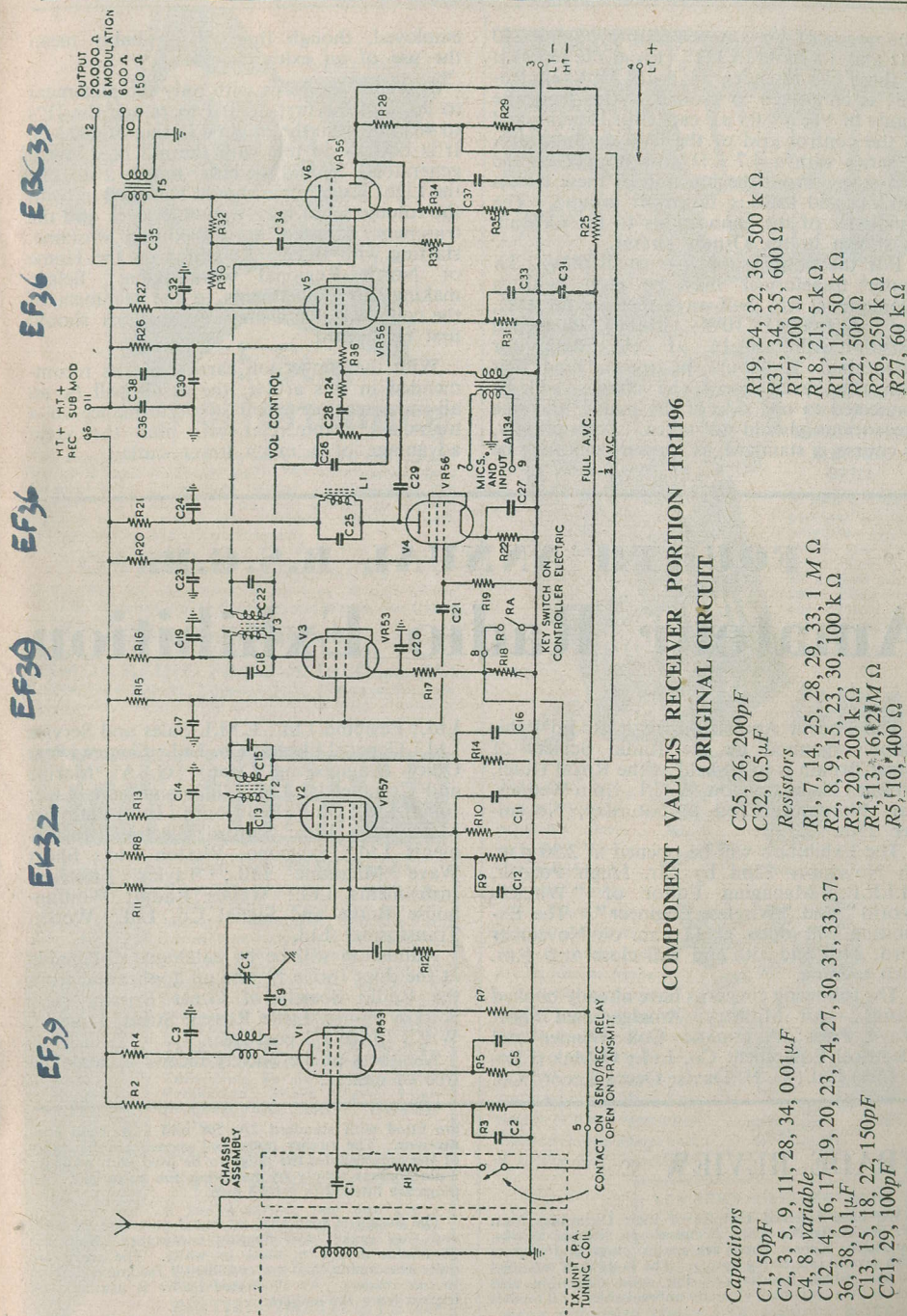

COMPONENT VALUES RECEIVER PORTION TR1196 ORIGINAL CIRCUIT

- Capacitors
 C1, 50pF
 C2, 3, 5, 9, 11, 28, 34, 0.01μF
 C4, 8, variable
 C12, 14, 16, 17, 19, 20, 23, 24, 27, 30, 31, 33, 37.
 C6, 38, 0.1μF
 C13, 15, 18, 22, 150pF
 C21, 29, 100pF
 C25, 26, 200pF
 C32, 0.5μF
- Resistors
 R1, 7, 14, 25, 28, 29, 33, 1 MΩ
 R2, 8, 9, 15, 23, 30, 100 kΩ
 R3, 20, 200 kΩ
 R4, 13, 16, 42 MΩ
 R5, 10, 400 Ω
 R19, 24, 32, 36, 500 kΩ
 R31, 34, 35, 600 Ω
 R17, 200 Ω
 R18, 21, 5 kΩ
 R11, 12, 50 kΩ
 R22, 500 Ω
 R26, 250 kΩ
 R27, 60 kΩ

The anode of V6 is now taken through a 250 kΩ and a 47 kΩ to HT. From the junction of these two resistors, an 8 μF 350V electrolytic is connected to ground. Also from the anode of V6, a 0.05 μF capacitor is connected to the control grid of the 6V6 output valve, in series with a 4.7 kΩ grid stopper on the grid side. From the junction of these two, a 500 kΩ grid leak is taken to ground. The remainder of the connections to the 6V6 are as shown in the Osmor circuit.

For the power supply, a small 6.3V 1.5A heater transformer may be used, with a selenium 60 mA half-wave rectifier for HT., and a 1,000 Ω 10W vitreous enamelled resistor with 16+16 μF electrolytic for smoothing. It should be remembered that with this arrangement the chassis will be connected to one side of the mains, and due precautions should be taken. Alternatively, of course, a standard AC power pack may be

employed, though this will probably mean the use of an extra chassis.

This now leaves us with only the alignment to do, and the first item is to retune the IF's to 465 kcs from the original setting of 460 kcs. It is best to do this with the aid of a signal generator. Should the latter not be available, the Light programme should be tuned in, with the volume set at barely audible level, and the trimmers adjusted for maximum volume, starting with IFT2. Re-adjust on the Home or North Regional wavelengths. Before making any adjustments to the trimmers of the coil pack, the Osmor instructions should first be studied.

With the conversion carried out as recommended in this article, the result will be an all-wave receiver equal in performance to a high-class commercial set, plus the great advantage of a much lower outlay.

FOURTH ANNUAL R.S.G.B.

Amateur Radio Exhibition

The Fourth Annual Amateur Radio Exhibition organised by the Radio Society of Great Britain is to be held at the Royal Hotel, Woburn Place, London, W.C.1., from Wednesday, November 22nd to Saturday, November 25th.

The Exhibition will be opened at 2.30 p.m. on November 22nd by Mr. Hugh Pocock, M.I.E.E., Managing Editor of "Wireless World" and "Wireless Engineer". The Exhibition will open at 11 a.m. on November 23rd, 24th and 25th and will close at 9 p.m. each evening.

The following concerns have already booked stands:—Air Ministry; Amalgamated Short Wave Press; Automatic Coil Winder and Electrical Equipment Co. Ltd.; Q-Max (Electronics) Ltd.; C. H. Davis; Decca Record Co.

Ltd.; Easibind Ltd.; E.M.I. Sales and Service Ltd.; General Electric Co. Ltd.; General Post Office (Engineering Dept.); G.S.V. Marine and Commercial Ltd.; Iliffe and Sons Ltd.; Imhof Ltd.; Oliver Pell Control Ltd.; Philpotts Metalworks Ltd.; Salford Electrical Instruments Ltd.; Sangamo—Weston Ltd.; Short Wave Magazine Ltd.; Taylor Electrical Instruments Ltd.; Webbs Radio; Westinghouse Brake and Signal Co. Ltd.; Woden Transformer Ltd.

Admission will be by catalogue obtainable at the door (price 1/-) or on application from the Radio Society of Great Britain, New Ruskin House, Little Russell Street, London, W.C.1 (price 1/3 post free).

Members of the Society receive a catalogue free of charge.

are fitted with standard 2A, 5A and 15A 3-pin connections. The rubber body and consequent flexibility of the pins enables the plugs to be used with ordinary 2-pin sockets simply by removing the earth pin. All plugs are fitted with a cord grip.

The design is such that no metal parts are exposed, and they make ideal floating connectors. Both are obtainable in brown, black or white. The prices are quite reasonable, and we confidently recommend them to our readers. An illustrated leaflet is available on request from the makers.

TRADE REVIEW

We have received samples of their Duraplugs from W. W. Haffenden Ltd., Richborough Rubber Works, Sandwich, Kent. These are mains plugs and sockets with several interesting points. The body is of moulded rubber, which besides ensuring good insulation also makes the component virtually unbreakable. All models



FIVE simple connections, the work of a few minutes and the job is done—and done well. No more wasted hours puzzling over complicated wiring circuits—with the OSMOR "Q" Coilpack, you just cannot go wrong! Portable battery model now available. Complete with full instructions and circuit diagrams.

OSMOR "Q" COILPACKS

As specified for conversion of the type 25 unit of the TR.1196, Wartime Utility Receivers and others. See article on Page 112. Send stamp for **FREE NEW CIRCUITS**, lists of Coils, Coilpacks, Dials and all Radio Components, etc. **OSMOR RADIO PRODUCTS (Dept. RC)** Bridge View Works, Borough Hill, Croydon, Surrey

OPPORTUNITIES IN RADIO

Get this FREE Book!

"ENGINEERING OPPORTUNITIES" reveals how you can become technically qualified at home for a highly paid key appointment in the vast Radio and Television industry. In 176 pages of intensely interesting matter it includes full details of our up-to-the-minute home-study courses in all branches of **RADIO AND TELEVISION, A.M.Brit.-I.R.E., A.M.S.E., City and Guilds, Special Television, Servicing, Sound-film Projection, Short Wave, High Frequency and General Wireless** courses.

We definitely guarantee "NO PASS—NO FEE"

If you're earning less than £10 a week this enlightening book is for you. Write for your copy to-day.

It will be sent **FREE** and without obligation.

BRITISH INSTITUTE OF ENGINEERING TECHNOLOGY
816 Shakespeare House,
17-19 Stratford Place, London, W.1.

Thousands are finding hours of profitable pleasure from Wolf Cub Home Constructor Equipment. Here is the new electric power way to do all the fitting and repairing jobs at home—beautifying the home—making useful presents for friends—modelmaking and scores of other handicrafts. Look at the astoundingly low price of the Wolf Cub electric drill and remember that it can be the power unit of all the Kits illustrated.

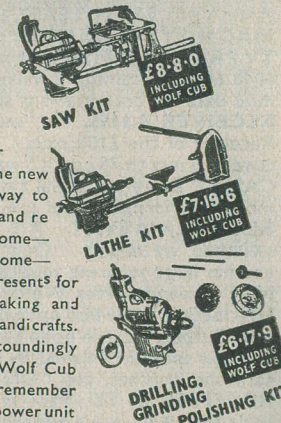

LOW PRICE CONVERSION SETS
Convert Wolf Cub or any Kit to form complete Home Constructor Equipment at attractive low prices.

Ask your tool supplier today for full details or write to:—

WOLF ELECTRIC TOOLS LTD. PIONEER WORKS,
HANGER LANE, LONDON, W.5. Tel.: PERivale 5631-4

Television Construction from Radar Receivers is extremely popular on account of the extreme sensitivity of these units, which give satisfactory results far outside the supposed "fringe" Areas. Cost is kept to a minimum, and once the receiver is working satisfactorily it can be incorporated into a Televisor using any size tube, if so desired. Remember also, that construction is the best way of learning "what makes Television tick". Several suitable Radar Units are listed below.

RECEIVER R. 1355 as specified for "Inexpensive Television". Complete with 8 valves VR65, and 1 ea. 5U4G, VUI20, VR92, and a copy of "Inexpensive TV". ONLY 55/- (carriage, etc. 7/6). Copy of book only 2/6.

I.F. STRIP 194. Another of the units specified as an alternative for the above. A first class strip giving tremendous amplification, and well recommended for constructors who have built televisors, but have come unstuck in the vision or sound receivers. Complete with 6 valves VR65, and 1 ea VR53 and VR92, also a copy of the book which gives simple mod data for both TV stations. ONLY 45/- (post 2/6).

"PYE" 45mcs I.F. STRIP. Ready made for London Vision channel. Complete with 6 valves EF50 and 1 EA50, also mod data. ONLY 60/- (Postage, etc. 2/6).

RECEIVER R.3547. This contains the "PYE" Strip as above, which is easily taken out if desired, and also 15 valves EF50, 3 of EB34, 2 of SP61, and 1 ea EA50, EBC33, EF36, also shoals of condensers, resistors, etc. An ideal chassis for building up. BRAND NEW IN MAKERS CASES. ONLY 120/- (carriage 7/6). Mod data supplied.

RECEIVER R.3084. A very sensitive unit containing 7 valves EF50, 2 EF54, and 1 ea VU39A, HVR2, EA50, and also a 30mcs IF Strip with 4mcs bandwidth. Well known to "long distance" constructors already. BRAND NEW IN MAKERS CASES. ONLY 75/- (carriage 7/6).

RF UNITS TYPE 25 for use with R.1355 for London TV. ONLY 17/6 (postage 1/6).

RF UNITS TYPE 26 for use on Sutton Coldfield channels are now all sold but we can supply the RF Unit 27 with full details of re-trimming to cover the TV. ONLY 35/- (Postage 1/6).

INDICATOR UNIT TYPE 6 as specified for "Inexpensive TV". Complete with VCR96 tube, 4 valves EF50 and 3 EB34. ONLY 67/6 used but good condition, or BRAND NEW IN MAKERS CASES ONLY 90/-. (Carriage on either 7/6). This unit is also specified for the "Wireless World" General Purpose Oscilloscope. Full constructional data available price 9d.

INDICATOR UNIT TYPE 62. Another unit containing the VCR 97 tube, and 16 valves VR65, 2 EB34, 2 EA50, and shoals of components. ONLY 75/- (Carriage, etc. 12/6).

MAGNIFYING LENS for 6in. tube. First grade oil filled. ONLY 25/- (Postage 1/6).

TV PRE AMPLIFIER for really weak areas can be easily made from the ex-RAF amplifier 6046/6050 containing 2 valves EF50, and giving very high signal to noise ratio. Full mod data for both stations supplied. ONLY 22/6 (Post 1/-).

RECEIVER R.1155. A "must have" for the enthusiast who wants a Communication Receiver of the £100 class. We have a few only of these superb 10 valve sets, which cover 7.5 mcs to 75 kcs in 5 wavebands, which are spotless and BRAND NEW IN MAKERS CASES. Every set aerial tested before despatch, and supplied with full details of easy mods for normal mains use. ONLY £12-10-0 (Carriage 12/6).

RECEIVER AEW 1. A 5 valve superhet covering 550-1600 kcs and 6-12 mcs in 4 switched wavebands. Operates from 6v D.C source through built in vibratorpack and has large separate speaker in metal cabinet with 50 ft extension lead. Made for the New Zealand Forces Welfare Dept, these sets have 2.5 watts output and are NEW & UNUSED. Valve line up: 6U7 RF Amp, 6K8 mixer, 6U7 IF Amp, 6Q7 2nd sdet 1t Audio, 6V6 Output. Large open slow motion tuning dial size 7in. x 3in. for ease of operation. Set and speaker finished in olive green crackle. An ideal receiver for country areas, caravans, coaches, etc. ONLY £9-19-6 (carriage 10/6).

RECEIVER 25/73. Part of the TR 1196. Covers 4.3-6.7 mcs, and makes an ideal basis for an all wave superhet as described in this journal. Complete with 6 valves; 2 ea EF36 and EF39, and 1 ea EK32 and EBC33. ONLY 22/6 (Postage, etc. 2/6).

Cash with order please (Phone TERminus 7937) Print name and address clearly

U.E.I. CORP, 138, Grays Inn Road, London, W.C.1.

Please note we are 2 mins from High Holborn (Chancery Lane Stn) and 5mins by bus from Kings Cross. We close 1 p.m. Saturdays.

OVERCOMING THAT MAINS DROP

A Topical Feature by J. R. DAVIES

SINCE the end of the war, the poorly-regulated mains supplies found in various parts of the country have been a source of annoyance to many users of radio equipment. A 230 volt supply that drops to say, 220 volts is not sufficiently bad to cause any trouble; but should it fall below 210 volts, then it is obvious that any electrical appliances connected to such a supply are not going to work at their best.

In addition, the writer has come across cases in England where the nominal 230 volt mains supply, during "peak" periods, has dropped below 190 volts! In one particular case, (in a country town), it was found impossible to get any reliable results from the domestic radio until the load had eased. Particularly was this true of Sunday mornings, when all the local electric ovens in the neighbourhood were in use.

Of course, the fault lies in the fact that new loads, introduced since the war, have proved to be too heavy for the original installations. The cure obviously lies in the replacement of obsolete equipment and wiring by the electrical authorities, but some years may pass before this occurs.

To overcome the effects of these varying voltages on radio equipment, the writer recently made up a unit as described in this article. This unit consists simply of an auto-transformer which may be switched to step up the mains to the required voltage, and a trip circuit which automatically switches off the equipment in use should the stepped-up voltage rise to too high a value. It was designed to overcome the conditions in a poorly-supplied district, and its action was sufficiently simple and fool-proof to enable it to be operated by any member of the household without disastrous consequences.

The Circuit of the Unit

A circuit of the unit is shown in Fig. 1. In this diagram it may be seen that the mains supply is passed to a switch which applies it to any of the various tappings on an auto-

transformer. The output, which feeds the equipment in use, is then taken from the top tapping on the transformer. Also in series with the output from the transformer are the contacts of a relay, these "making" when the relay is de-energised.

To ensure that, owing to a rise in mains voltage, excessive voltage is not supplied to the output circuit, a trip switch is incorporated. This consists of a rectifier and a neon stabilizer or similar valve. The rectifier, fed from a pre-set potentiometer connected across the output from the auto-transformer, supplies a DC voltage to the neon lamp via the relay coil. When this DC voltage exceeds a certain pre-determined value, the neon strikes, passing a relatively high current and causing the relay to be energized; thereby switching off the current to the equipment connected to the output. Once it has struck, the neon stays alight and no output is available until the tapping switch has been re-set to a higher and safer value. It will be found in practice that the trip circuit is very sensitive and always comes into operation at exactly the same voltage.

The Components Needed

It is obvious, in making up a unit of this type, that there is little point in purchasing new items if one can use components already on hand, or which may be cheaply bought in the surplus market.

The auto-transformer used by the author, for instance, was an ordinary "heater transformer" with a tapped primary which happened to be on hand. The heater winding was used, incidentally, to light a pilot lamp showing that the unit was switched on, but this is, of course, by no means necessary. If the unit were designed for use with, say, a television receiver a larger transformer might be needed. A small transformer should be quite sufficient for a normal radio receiver or similar item of equipment, however.

The relay used by the writer was a high-resistance job, which closed at about 5 mA

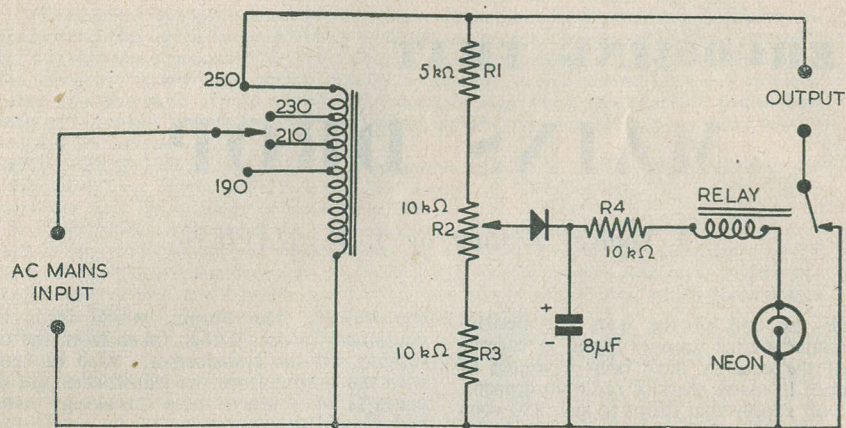

Fig. 1: Circuit of the vari-unit described in this article.

energizing current. The coil winding had a resistance of some 1,000 ohms. These relays appear to be fairly easy to obtain in the surplus market. The rectifier is a small metal component, capable of passing 30 mA, and, in this case, was wrested from the entrails of a long-disused battery eliminator.

The resistors should all have a rating of at least one watt. The average neon stabilizer will strike at about 170 volts or so, so that all that is really needed is some form of potentiometer circuit which will allow this voltage to be applied to the neon after rectification. The potentiometer proper (R_2) should be a wire-wound component. The values of R_1 , R_2 and R_3 are not very important, but they should be low enough to allow 10 mA or more to flow through the potentiometer network itself. Of course, it would be possible to use one component only: say, a single 20,000 ohm variable potentiometer connected across the whole of the output voltage, but this would make the setting-up of the voltage trip somewhat difficult, and the results might be unreliable.

It will be seen that a fairly large capacitor is used to smooth the rectified DC. This is necessary for two reasons. Firstly, the relay is liable to "chatter" unless the DC is fairly smooth. Secondly, before the neon strikes, this capacitor will charge up to the peak AC voltage applied to the rectifier; whereas, as soon as the neon strikes and begins to draw current, the rectified voltage will drop considerably unless there is a sufficiently large

reservoir capacitor to keep this voltage reasonably high. An 8 μ F capacitor was found quite sufficient in practice. It is also due to the fact that too much voltage may be dropped when the neon strikes that it is necessary to use low-value resistors for the potentiometer circuit.

The resistor R_4 , in series with the neon, is used as the normal neon limiting resistor. The value chosen in the diagram, (10,000 ohms), should be sufficiently useful for most types of neon stabilizer, but a reduced value may be used if necessary.

Obtaining the stabilizer itself should not prove very difficult, as almost any type of neon may be used. That used by the writer was an ordinary neon stabilizer valve, and had two concentric rings for the electrodes. This form of construction gave rise to a bright red glow when the neon struck and it was therefore mounted on the front panel to give a visual indication of the fact that the trip had operated. Such valves as the VR 150/30, etc., would be perfect for a job such as this; but, as they do not glow very brightly when struck, would not be very useful for visual indication. An ordinary bee-hive neon lamp would probably work quite well, although it might not be so reliable in use as a stabilizer valve. It should not be forgotten that most neon bulbs which are used for lighting purposes have series resistors fitted in the base. Of course, it must be remembered that the neon is not used for its stabilizing properties, but because it always *strikes* at the same voltage.

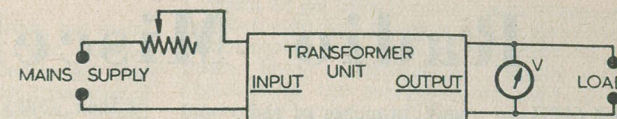

Fig. 2: Showing how the unit is initially adjusted.

C20

Finally, let us consider the switch used to select the various auto-transformer taps. It is necessary to use a switch which can not only handle the current required but which will also completely break the circuit between tappings. Thus, should the mains voltage rise sufficiently to operate the trip, turning the switch to the next tapping will automatically break the primary circuit, causing the neon to be extinguished, and thereby putting everything back to normal for the next position.

Setting-up the Unit

To set up the trip circuit, the unit should be connected up as shown in Fig. 2. A load is connected to the output of the unit and is

shunted by an AC voltmeter. To obtain a varying mains input, a variable resistor (or similar device) is connected in series with the mains and the input to the unit. The tapping switch and the resistor are then adjusted to cause the required trip voltage to be applied to the load. That is to say, if the load were designed for 230 volt operation, the adjustments would be made to apply, say, 235 volts to the output, (as shown in the meter). The pre-set potentiometer is then slowly turned up until the neon just strikes. The setting may be checked by switching off the unit to de-energize the neon and then varying the load voltage between say, 230 and 240 volts to ensure that the trip operates always at the correct voltage.

EHT Unit for 7/6

Dear Sir,—Re your article in the October issue entitled "EHT Unit for 7/6" by H. W. Arundel, please allow us to state that this is the store where the notice inscribed "It's Your Birthday, All This For 5/—, Less Valves" was displayed, in connection with the Power Unit type 225. This offer was made for a short time only, as far as twelve months back, in order to clear a dozen or so of the large units which, of course, were minus valves. After this offer ceased, further supplies of type 225 Power Units were much more costly to obtain under M.O.S. Sales. Being uneconomical for us to sell this unit as it exists, for the past twelve months we have employed people to dismantle them and, working out the cost of labour, we find that to make a fair profit we have to market the transformers taken from these units at 7s. 6d. each.

The following data on these transformers may be of interest to readers :

10KB/794: Input, 80V 2000 cps. Output, 5000V RMS, 25 mA.

10KB/795/796: Input 80V 2000 cps. Output, 4000V RMS, 25mA.

We find that a safe limit for the primary voltage is 36, and this is obtained by using a 4.5 μ F capacitor in series with the primary in each case. The outputs shown on a 2000 Ω per volt meter are as follows, the reservoir capacitor being 0.1 μ F in each instance: 10KB/794 gives 3600V with 0.5 mA load. 10KB/795/796 give 3300V with 0.5 mA load.

In your article it is stated that these transformers are available for about 2s. each. For your information, we do not know of any store which has these transformers to sell at this price. Even at our price of 7s. 6d., we think you will agree that it is an excellent buy, particularly as the insulation of these transformers is 20,000V.—S. Kershaw (Kershaw's Korner, Pershore Street, Birmingham 5.)

Radio Miscellany

WITH so many branches of radio and electronics to occupy the interest of the constructor to-day, it is not surprising that many find it impossible to keep up with so wide a range, and tend towards greater specialisation. Twenty years ago there were, broadly speaking, only three main interests to which the constructor might turn his attention, once his introductory burst of enthusiasm had carried him beyond ordinary receiver design. The receivers of those days, too, were of infinitely simpler design although, of course, quite adequate for their period. The design of a first class modern receiver requires almost as much knowledge of the construction and use of other equipment as of the receiver itself.

The pre-war enthusiast, if he was not greatly attracted by short-wave listening or amateur communication radio, usually turned his attention to high quality reproduction. Despite their considerable numerical strength, the quality fan has perhaps not been as fully catered for in radio journalism and text books as he deserves. At one time there were several flourishing clubs catering for him, but today he seems to be something of a lone wolf. Yet who can doubt his importance in the face of so steady a demand for high quality speakers, amplifiers, expensive pick-ups and elaborate labyrinth baffle speakers?

Many constructors possess an acute ear, or a feeling for music, and to them the problem of sound reproduction with its many complexities becomes so absorbing that they find little interest in other branches of the hobby. Indeed, the quest for a truly balanced and life-like reproduction leaves little time for much else.

Ostracism.

The perfect reproduction would, of course, be indistinguishable from the original sound, but has any reader ever been deceived that he has been listening to the natural voice or the live orchestra instead of a reproduction?

Again, too, the question of maintaining high quality at low volume levels, as well as at high, is a difficult one.

The first real step forward in widening the range of reproduced sound was at the bass end of the scale. Older readers will well remember the early moving coil speakers and the thrilling "woof" they made at the bottom end of the musical register. The radio-man and the general public fell for them in a big way. We put them on to enormous baffle boards just to be sure we made the most

of their ability to thump out the low notes. Happily, one did not need to be a millionaire or a black marketer to get hold of a few square yards of 5-ply in those days.

Did they rattle the ornaments on Mrs. Next-door's mantelpiece? I'll say they did, and the enthusiast often encountered social ostracism as a consequence.

The BBC, Too!

Then the studios took a hand. Orchestral instrumentalists found themselves shuffled all around the studio, and the double bass was often put right up beside the microphone. The big grunting boom was selling point No. 1, and manufacturers and salesmen ecstatically cried "Just listen to the bass." No invitation was necessary really—it simply jumped out and hit you. In fact I was once solemnly assured by a listener that the thirty cycle sound waves from an early moving-coil speaker impinged so violently on the wall of his stomach when he stood facing it, that they produced a feeling of physical sickness!

Even to this day, the public feels that all the best sets should have plenty of bass. They have learned to love it, and an inspection of domestic receivers reveals that nine-tenths of listeners use the "tone" control to give maximum bass accentuation, completely oblivious of the top cut entailed.

The manufacturers euphemistically called that position "mellow", and if a musically minded listener dares to shift the control to give the top a chance, the reproduction is immediately condemned as being harsh and shrill.

It would seem that the ordinary listener does not want good reproduction. His ears have, by the continual acceptance of "pleasing" noise, been drugged by distortion and he finds an imagined realness behind what is often a travesty of the original. Listeners have grown to dislike a different "tone" from the one to which they have become accustomed. It is far from infrequent to find extension speakers that are twenty years old, and to have their owners tell you they prefer them to anything else they have ever heard! Possibly more people than we suspect are tone deaf, but in any case there is but little improvement in the performance of the cheaper class of speaker. I am sure many would be unable to distinguish by sound alone between a speaker of 1936 vintage and a 1950 model when connected to a properly adjusted receiver.

Brilliance

Perhaps it is human perverseness, but many quality enthusiasts go to the other extreme and make all sorts of sacrifices to get that little bit of extra top, even to tolerating a terrific needle hiss on gramophone reproduction. More than once I have been assured "You don't notice it after a while". This strikes me as a funny attitude. If one can adjust one's hearing not to notice it, surely it would be just as easy to adjust oneself not to notice other deficiencies.

The early quality enthusiasts were quick to perceive the propaganda value of the term "mellow", which was freely used to accustom people to reproduction which was sadly lacking in top. The purists retaliated by calling reproduction, which the ordinary listener called shrill, as having "attack" or "brilliance", and won over quite a number of converts who had not been too strongly drugged by the glamour of a thumping bass—but the general public remained unmoved. They liked a "pleasing" middle with a good helping of bass thrown in. If it wasn't really natural they soon grew used to it, and they were quite happy to pretend that it was.

Radio manufacturers, even if they are not psychologists, are at least good business men, so they gave the public what they demanded. Probably the manufacturer shrugged his shoulders and decided there was no sense in getting rid of one lot of imperfections (for which the public had acquired a taste) merely for the sake of trying to educate them to accept another (which they might not like so much after all). Anyway, their business is to sell sets, and to do that you have to give the purchaser what he likes best.

When we get back to earth, we must remember that, even with the most perfect amplifying systems, there are still other factors to be taken into consideration. Firstly, the acoustics of the average room need to be taken into account, but given that, one still finds that there is a lot of correction to be done to balance the intensity of the pianissimo and fortissimo passages. Both in broadcast and recording studios the contrast is "compressed". This is essential while the normal output stage is unable to handle the loud passages if adjusted to give a satisfactory level on the soft passages. With record reproduction, the pianissimo must be at least strong enough to overcome needle noise, and a proportionate fortissimo would not only overload the amplifier, but also damage the record surface.

Many thoughtful enthusiasts have an instinctive dislike of what must truthfully be described as "faking"—by the balancing of one imperfection against another. Generally speaking, that is the principle that must be exploited in the search for better quality.

If you have an acoustically good room, plenty of time and a taste for it, you can get years of fun in the quest for high fidelity. Personally I would advise making a start with improved, and simplified, methods of contrast expansion—to put back what the studios take out before you receive it!

Close-Up

Talking of faking, the art (or should it be artifice?) of crooning was surely born in the trick use of the microphone. It is essentially a form of cheating, and for its success it depends upon amplification to gain an otherwise unobtainable effect.

I have never seen the technique of crooning

CENTRE TAP talks about QUALITY REPRODUCTION - CROONING

Plenty of Scope

Personally, I have always regarded the striving after super reproduction as something of an illusion, and it has been a source of mild surprise to me when I think of the trouble and money enthusiasts have expended on getting a little more emphasis at either end of the musical register. I shouldn't be, really. Having been a rainbow chaser most of my life, I know just how much fun it is chasing something that is tantalisingly beyond your reach.

defined, but personally I should describe it to mean singing softly and intimately into the microphone, with a few sobs thrown in to give it appeal and tenderness. By greatly amplifying the resultant sound, the depth, volume and apparent realness of a rich and strong (but counterfeit) voice is simulated.

If sound reproduction can be debased for such deceit, how much more justified is the radioman's balancing of two imperfect factors to give a semblance of reality to worthier music?

PRACTICAL AERIALS

by "AETHERIUM"

Part 3

Directional Aerials

Another excellent type of fixed bi-directional aerial is the V beam, (Fig. 1). This aerial, however, requires plenty of space, especially for operation on the lower frequencies. For instance, to obtain the worthwhile gain of 8 dB on 14 Mcs each leg of the beam would have to be 4 wavelengths long or 279 feet, with an included angle of 50 degrees. This factor prohibits the erection of this aerial in the average garden, at any rate for the lower frequencies. For bi-directional work on the VHF bands, however, it becomes a proposition, and this will be dealt with in a later chapter.

The Rhombic is another type of aerial requiring a prohibitive amount of space. A 3 wavelength Rhombic for 7, 14 and 28 Mcs designed to give approx. 10 dB of gain on 28 Mcs would require a total ground space of 590 feet by 214 feet. This aerial also has possibilities at VHF, as will be seen later. The Franklin aerial (Fig. 2) or co-linear array is another bi-directional aerial, more suitable for operation on 7 Mcs and lower, because of its high angle radiation pattern.

Directional Aerials
The Lazy "H"
The Sterba Curtain
The Folded Dipole

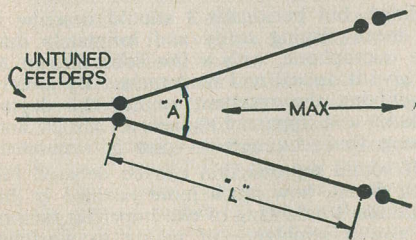

FIG 1: V AERIAL

FOR L' IN WAVELENGTHS	A°	VERTICAL RADIATION ANGLE	GAIN APPROX
2	70°	27°	6dB
3	60°	23°	7dB
4	52°	20°	8dB
5	45°	18°	9dB
6	40°	16°	10dB
7	37°	15°	11dB
8	35°	14°	12dB

C85

From a practical point of view, the Franklin aerial is not worthwhile for Amateur work. The gain of a 4 element aerial of this type is only about 1 dB greater than a dipole with driven reflector, and it would have only about half the coverage (i.e. 30° back and front).

The Lazy 'H' Aerial (Fig. 3)

This is a very popular aerial for 28 Mcs work, although it may be used quite effectively on 14 Mcs. For 28 Mcs operation it may be made rotatable. As a fixed bi-directional beam its gain is approx. 6 dB (4 times the power) and if fitted with reflectors, this gain is increased to approx. 9.5 dB (8 times the power). The stacking of the elements vertically produces radiation at the low angles (the vertical radiation pattern is shown in Fig. 4), which makes it a particularly suitable type for operation on the two higher frequencies, 14 and 28 Mcs. The fitting of reflectors, while increasing the gain as stated, also limits the coverage, and it becomes necessary to rotate it a full 360 degrees in order to cover the horizon. Owing to the difficulty in supporting

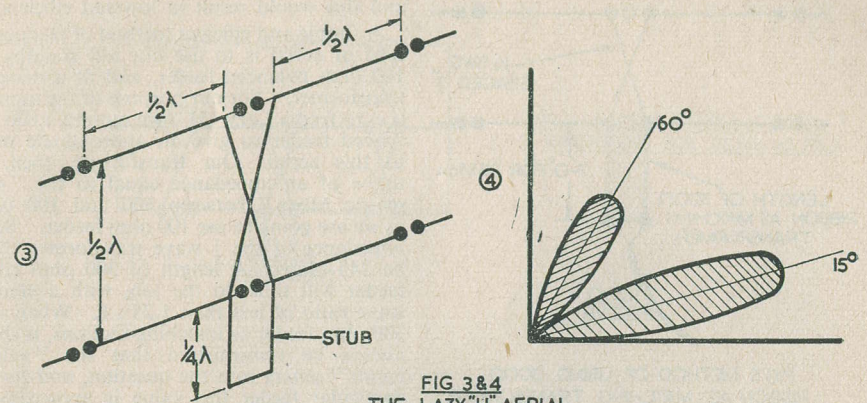

FIG 3&4 THE LAZY "H" AERIAL WITH ITS VERTICAL RADIATION PATTERN

FREQ. Mcs	EACH RADIATOR	EACH REFLECTOR	SPACING REFLECTOR TO RADIATOR
28.0	16'-7"	17'-10"	8'-10"
28.5	16'-4"	17'-6"	8'-4"
29.0	16'-0"	17'-0"	8'-0"

FIG 4A OPTIMUM DIMENSIONS & SPACINGS FOR LAZY 'H' AERIAL FITTED WITH 1/4 lambda SPACED REFLECTORS

C87

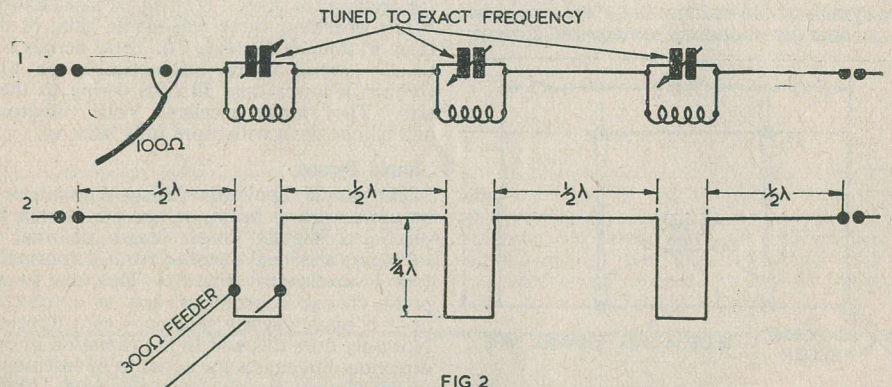

FIG 2 TWO VERSIONS OF THE FRANKLIN CO-LINEAR AERIAL
1. FOR 100Ω FEEDER & TUNED CIRCUITS
2. FOR 300Ω FEEDER & TUNED STUBS

C86

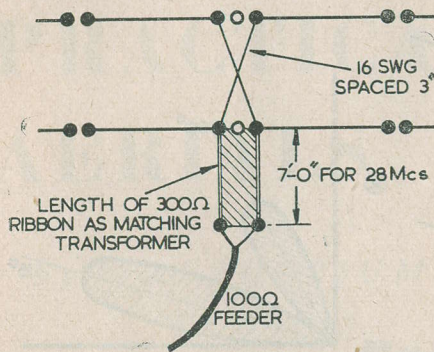

FIG 5 METHOD OF USING 300Ω RIBBON AS MATCHING TRANSFORMER

C88

the elements, due to the length they attain on 14 Mcs, the Lazy 'H' is normally only used on 28 Mcs (and higher) as a rotary aerial. Fig. 4a gives optimum dimensions, reflector spacings, and lengths for operation on 28 Mcs.

Feeding the Lazy 'H'

It will be remembered that we fed the dipole at a low impedance (or current) point. The Lazy 'H' aerial contains 4 half wave dipoles which are fed at the ends (high impedance or voltage point). Any attempt to use low impedance feeder would result in absolute failure to obtain a match. We could, of course, forget the stub (Fig. 3) and feed in half way along one of the lower elements. The system would radiate, but there would be an unequal distribution of voltage and current,

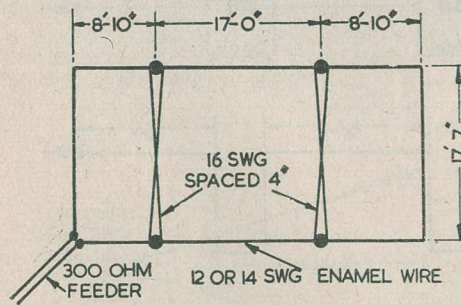

FIG 6 SIMPLE "STERBA CURTAIN" WITH OPTIMUM DIMENSIONS FOR 28 Mcs OPERATION

C89

and this would result in lowered efficiency.

A simple and efficient method of feeding this type of aerial is to use our old standby, the 100 ohm balanced feeder, and fit a matching transformer. For our purpose of the moment, (i.e. to feed a Lazy 'H') we require a 600 ohm spaced feeder to give an approximate match to this aerial. Our transformer, then, has to be of an impedance equal to the "Geometric Mean" between 600 and 100 ohms, as we are going to use 100 ohm feeder. So the impedance of the 1/4 wave transformer should be 245 ohms. A length of 300 ohm ribbon feeder will thus do the job, with a standing wave ratio of less than 1.25 : 1. When using 300 ohm feeder as matching sections, it should always be remembered that the "velocity factor" enters into the question, and for this particular feeder this value is approximately 0.8. This means that your quarter wave section has to be 0.8 of a quarter wave. Connections and lengths are shown in Fig. 5. Some may prefer to use the stub and spaced-feeder method of feed, but from the point of view of efficiency there is very little to choose between the two methods.

The loss factor of 100 ohm BA.3 feeder at 28 Mcs. is only of the order of 2 dB per 100 ft.

The Sterba

Sterba 'curtains' consist of arrays of half-wave elements stacked vertically, the ends being terminated in quarter wave sections as shown in the typical example given in Fig. 6. This particular one may be fed direct with 300 ohm feeder. For a multiple array as shown in Fig. 7, feeding should always be done at the centre, and the method adopted for feeding the Lazy 'H' will be satisfactory. While providing quite reasonable gain, (8 dB (Fig. 6) and 10 dB (Fig. 7)), these aerials are usually found to be impracticable on any frequency lower than 14 Mcs owing to their size. They make excellent VHF radiators, and will be dealt with more fully later on.

Simple Beams

The simple dipole (or half-wave aerial) may be turned into a beam, or one-way aerial, by placing a slightly longer length of wire or tubing at a critical distance from it (normally 1/2 or 1/4 wavelength) (Fig. 8). This, due to the phase change it produces, acts as a reflector or — if made slightly shorter — as a director. Not only does this add to the radiation in one direction, but causes the aerial to be insensitive to interfering signals from the rear. These "parasitic elements", as they are called, also lower the impedance of the feed point of the driven element, so that we are now faced with the problem of finding a suitable feeder which will match into an impedance of something

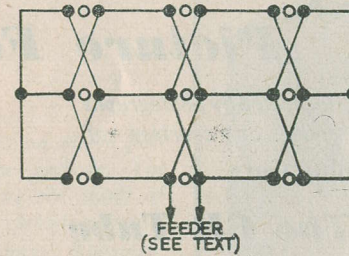

FIG 7: MULTIPLE STERBA CURTAIN DIMENSIONS FOR 28 Mcs AS FIG 6

C90

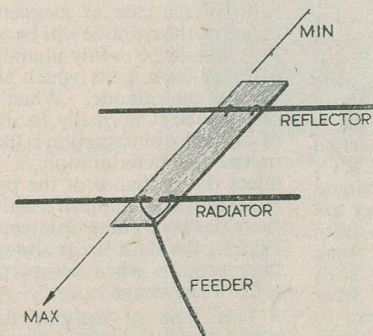

FIG 8

SIMPLE DIPOLE PLUS PARASITIC REFLECTOR (OR TWO-ELEMENT BEAM).

NOTE: IMPEDANCE AT FEED POINT IS CONSIDERABLY LOWER THAN BEFORE REFLECTOR WAS ADDED.

C91

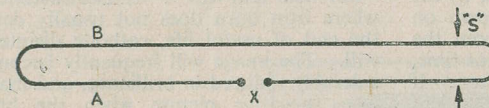

FIG 9: FOLDED DIPOLE IMPEDANCE AT X IS GOVERNED BY SPACING 'S' & WHEN CONSTRUCTED FROM TUBING BY RATIO OF SIZE OF RADIATOR 'A' TO FOLDED PORTION 'B'

C92

like 40 ohms (as in the case of the dipole with 1/4 wavelength spaced reflector). 50 ohm feeder would, of course, be a fairly good match, but a far better way out of this difficulty is to increase the impedance of our beam and thus make it to suit our feeder. This may be done

by the simple method of "folding" the driven element (Fig. 9). By the ratio of the size of the folded portion to the main radiator, and the spacing between them, we shall see how the impedance of the driven element may be adjusted to suit almost any type of feeder.

(To be continued)

★ Commencing next issue

MAGNETIC SOUND RECORDING

TELEVISION

Picture Faults

Part eight of a series, illustrated by photographs from a Televisor screen by courtesy of

Mr. John Cura.

Part 8 - The CR Tube

AS the most expensive individual component, the safety of the cathode ray tube is foremost in the minds of all constructors, when testing or adjusting a televisor. However, a few simple precautions will render any possibility of damage fairly remote, and a little careful thought as to what procedure to adopt is very worth while.

Firstly, handling the tube must be carried out with extreme caution. As a rule, CRT's are fairly robust — they have to be to withstand the high external air pressure which they are subjected to. But they are hardly safe from rough treatment and have several weak points. These are the neck, base, air seals and anode pips. It is advisable to wear goggles or glasses, when handling them, to protect the eyes. A cut from flying glass may not be a serious matter, but the possibility of eye damage is a different proposition. Always lift the tube with both hands, and never by the neck. It may be left standing face down on some soft material when removed from the receiver, but if it is to be left out for some time, should be replaced in the original carton. If these points are carefully noted, an accident is very unlikely to occur.

Electrical damage is generally confined to the electrode assembly. Starting with the heater, and working towards the screen, the following faults and their causes are detailed.

Heater and Cathode

On installing a new tube, check most carefully that the heater supply is of the correct voltage. Tubes of British manufacture, may, have heater voltages of 2, 4, 6.3, or 10, and doubtless in the future other heater voltages may appear.

The heater voltage must be correct. If exceeded, the cathode may lose its emission rapidly, and if under-run, the picture given will be of very poor quality, at the least. Cathode disintegration will arise when the heater is over-run, and large portions of the cathode area will lose the ability to emit electrons. If the tube is operated with heater, bias and EHT

supplies, but without focusing potentials in the case of electrostatic tubes, and magnetic fields in the case of magnetic tubes, then an image of the cathode will be seen on the screen. This should be evenly illuminated, and be free of large dark areas which show non-emittive areas of the cathode. When the electron beam of the tube is normally focused, no indication of cathode disintegration is likely to be obvious, unless the deterioration is so serious as to affect the brilliance of the picture as a whole. An excellent example of a cathode image, where there has been some disintegration, is shown in Fig. 1, the dark areas showing the degree of deterioration when compared with the total area of the image.

This type of cathode damage may also appear when the CRT is reaching the end of its life; in this case, the heater supply may not be at fault and the effect may be attributed to "fair wear and tear". In electrostatic tubes, where iron burn does not usually determine the end of useful life, cathode disintegration will. The image will frequently become considerably reduced in brilliance, and may show as a negative picture when the brilliance control is increased beyond the usual setting. It may not be possible to obtain a cathode image with electrostatic tubes, due to interference of the wide cathode beam by the electrode assembly.

Modulator Grid

The modulator grid of the CRT, and the other electrodes further from the cathode, seldom have faults of their own. Adequate insulation is provided in the construction, and they are mechanically strong. There is the possibility, however, of small particles of screen or cathode material falling into the small gaps between electrodes, and causing short circuits. This is most likely to happen between the modulator grid and the cathode, the latter being almost completely enclosed by the cylinder which forms the grid. Small particles of cathode material falling into this cylinder do not easily escape, and may bridge the

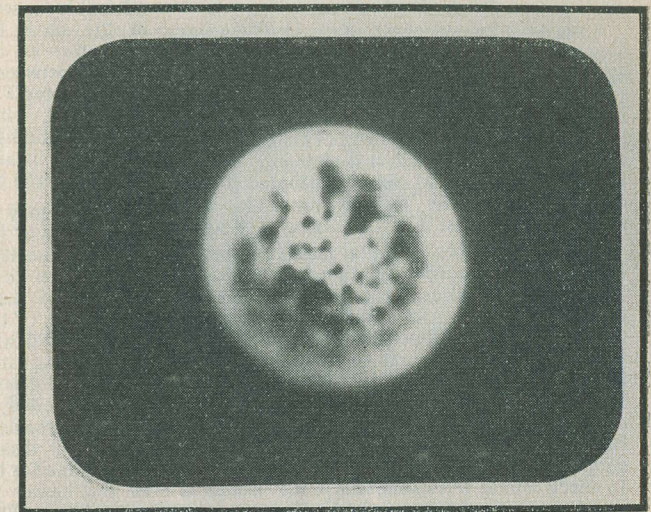

Fig. 1: Image on screen produced by the cathode. The dark areas are the result of flaking of the cathode material, showing advanced disintegration.

(John Cura 'Tele-Snap')

electrodes, causing the grid potential to rise to that of the cathode, with subsequent lack of control of brilliance. It frequently becomes apparent when the receiver is first switched on, and after some minutes, the expansion of the elements forming the electrode system allows the fault to clear, and the tube then operates normally.

If the fault becomes persistent, and ceases

to clear after the televisor has been on for some time, the tube must be considered a loss. It may possibly be salvaged by drastic treatment such as "flashing" between the electrodes concerned, or by gently tapping the tube to dislodge the bridging material. From experience, this latter method seldom has the desired effect, and is somewhat dangerous; precautions should always be taken to protect

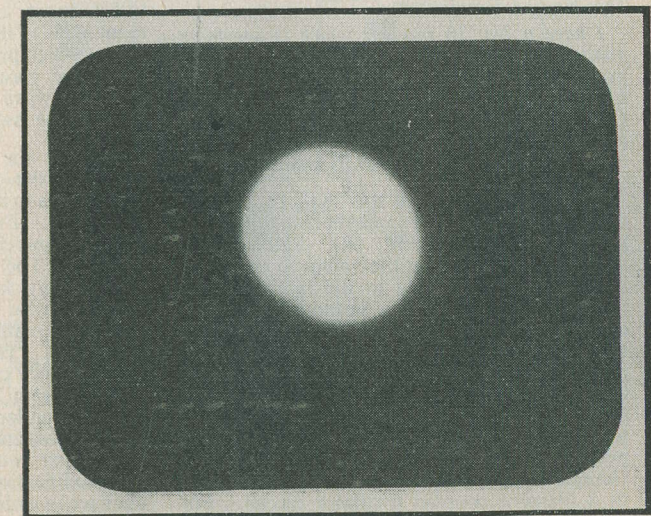
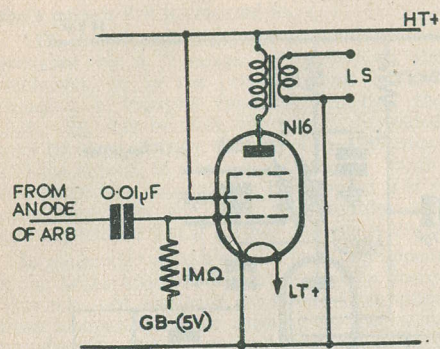

Fig. 2: Image resulting from a normal cathode.

(John Cura 'Tele-Snap')



C96

Fig. 3: The output stage.

conversion is perfectly straightforward; the only possible trouble which could occur is that of squegging, and this may easily be overcome by increasing the value of the stopper resistance R1 in the oscillator grid circuit. Fig. 3 indicates the circuit diagram of the additional output stage. The lead which is taken from the anode of the AR8 to the grid circuit of the output valve should be screened in order to prevent instability, whilst the phone trans-

former may be left intact. This transformer provides an effective anode load for the AR8 when the phones are not connected, and maximum stage gain is obtained. When the phones are connected however, the effective load is reduced together with the output from the speaker; this is not a disadvantage as the loudspeaker is not required when using phones.

For those short wave enthusiasts who only wish to use the receiver for long range reception, it might be desirable to simply modify the frequency changer stage as recommended whilst leaving the untuned RF stage intact. This will of course enable the maximum sensitivity to be obtained, but does not leave space for the addition of an output stage. However, as the majority of short wave listening will be with headphones this is no serious disadvantage. We feel confident in saying that, for the constructor who does not mind spending a certain amount of time in modifying this receiver, it is certainly a good buy at its present ex-Government price, and provides a useful portable for either general or field day use.

Time Constant

I understand that when a capacitor is charged through a resistor the voltage across the capacitor rises gradually to its maximum value; would you please inform me of the method whereby the value of this voltage may be determined after any given time?

S. A. Roberts, Hillingdon.

Readers who may fear that we are about to delve into a treatise on the use of mathematics in radio calculations are assured that this is not the case and should take heart and read on. There are many problems which cannot be solved without resource to maths, but provided simple logarithms are acceptable then the following will present no difficulties. The diagram Fig. 4 shows a capacitor which is connected via a resistor to a battery. Now, before the battery switch is closed the capacitor holds no charge, and hence there is no voltage across its terminals. When the switch is closed a current flows around the circuit, and because initially there is no charge on the capacitor this current is limited only by the resistor. The value of this current at the instant of closing the switch may be simply

calculated by means of Ohms law, $I = \frac{V}{R}$.

However, as a charge builds up across the capacitor the voltage across it increases, and therefore the voltage across the resistor decreases. At any particular instant these two voltages will add up to the battery voltage,

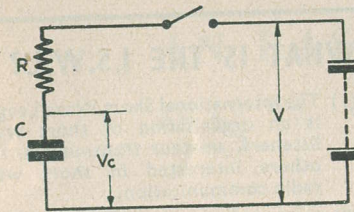

C97

Fig. 4: A capacitor charged from a battery via a resistor.

thus as one increases the other will decrease. Also, as the voltage across the resistor decreases the current in the circuit will fall until it finally reaches zero. At this stage, then, the capacitor is fully charged and the voltage across it equals the battery voltage. Reference to Fig. 5 shows how the current in the circuit, and also the voltage across the capacitor, changes with time immediately after the battery switch is closed. Now the problem is to calculate the value of either of these parameters at any instant of time after the closing of the switch, and this entails the use of a simple formula.

At any time, which we will call 't' seconds, after switching on the current is given by:

$$i = \frac{V e^{-\frac{t}{CR}}}{R}$$

where V = battery voltage
R = value of resistance (ohms)
C = value of capacitance (farads)
e = base of Napierian logs = 2.71828.

This may appear a little formidable at first sight but a worked example should help to clarify matters. Assume that V=1000 volts, R=1 Meg Ω, and C=1 μF, then at the instant when the switch is closed the current will be

$$I = \frac{1000 \times 10^3}{1 \times 10^6} = 1 \text{ mA. by Ohms Law}$$

After half a second the current will have fallen to:

$$i = 1 \times 2.71828^{-\frac{0.5}{1}}$$

Since $\frac{V}{R} = 1 \text{ mA}$ and $CR = 1$

Working out by means of logs we obtain
 $\log i = \log 1 - 0.5 \log 2.71828$
 $i = 0.6 \text{ mA.}$

The voltage across the capacitor when the current is at this value may be determined by subtracting the voltage which appears across the resistor at this instant from the supply voltage.

$$\text{thus } V_c = 1000 - iR \\ = 1000 - 600 = 400 \text{ volts.}$$

Calculations of this type are particularly useful when working out the component values of a time base, as the majority of these oscillators operate on the principle of a capacitor charged via a resistor. Finally, it is interesting to note that the value of 'CR' is known as the time constant of the resistance-capacitance combination, and is the time in seconds required for the voltage across the capacitor to reach 63.2% of its final value.

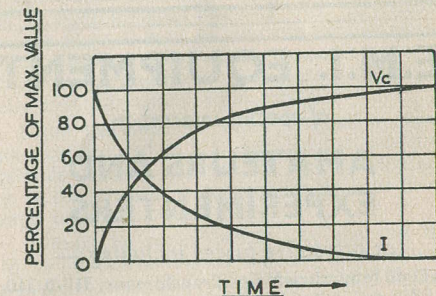

C98

Fig. 5: Showing how the voltage and current alter with time.

QUERY CORNER

“ Rules ”

- (1) A nominal fee of 2/- will be made for each query.
- (2) Queries on any subject relating to technical radio or electrical matters will be accepted, though it will not be possible to provide complete circuit diagrams for the more complex receivers, transmitters and the like.
- (3) Complete circuits of equipment may be submitted to us before construction is commenced. This will ensure that component values are correct and that the circuit is theoretically sound.
- (4) All queries will receive critical scrutiny and replies will be as comprehensive as possible.
- (5) Correspondence to be addressed to "Query Corner," Radio Constructor, 57, Maida Vale, Paddington, London, W.9.
- (6) A selection of those queries with a more general interest will be reproduced in these pages each month.

Book Review.....

TESTING RADIO SETS. By J. H. Reyner. B.Sc., A.C.G.I., D.I.C., M.I.E.E., M.Inst.R.E. 215 pp. Chapman and Hall, Ltd., 37 Essex Street, London, W.C.2. 5th revised edition. Price 22s. 6d.

Attractively produced and well illustrated, this book covers the subject of testing receivers in a number of stages, commencing with a discussion on system and equipment. Next,

the various types of stages encountered, such as RF, AF, Tuning and Power Supplies, and the faults peculiar to each are exhaustively dealt with. The next two chapters describe receiver and component tests, followed by a chapter on the cathode ray oscillograph. Finally, there is a chapter on curious faults.

B.C.

RADIO AMATEUR ENTHUSIASTS

and

PROFESSIONAL W/T OPERATORS

The Candler System of Morse Code Training has been demonstrating its value for the past 36 years.

Each CANDLER SYSTEM Course (JUNIOR for Beginners—ADVANCED for Operators) is arranged in a series of 10 progressive lessons which are fascinating, instructive and practical. They teach you the most vital principles of telegraphing technique, the fundamentals of successful, efficient, accurate and speedy Receiving and Sending of the Morse Code.

Full details of the Candler System Courses in

MORSE CODE TRAINING

are set out in the Candler "BOOK OF FACTS" which will be sent you post free and without obligation. Courses supplied on Cash or Monthly payment terms.

THE CANDLER SYSTEM CO.

(ROOM 55C) 221 KINGSWAY, LONDON, W.C2.
Candler System Co., Denver, Colorado, U.S.A.

E.M.I. EQUIPMENT

of special interest to

AMATEURS AND EXPERIMENTERS

at attractive prices including:—

AD 40 Miniature Mains Transformer, 310-0-310, 4v. 6.3v. 230-250v. input, 65-80 m.a. current rating: 13/6 plus 1/6 postage.

AD 41 Mains Transformer, 325-0-325, 4v., 6.3v. 100-250 v. input. App. 100 m.a. current rating. 19/6 plus 1/6 postage.

AS 16 Smoothing Choke. Approx. 8 hys. 200 m.a. 250 ohms D.C. Res. 6/6 plus 1/6 postage.

Also available in limited quantities:—

AMPLIFIERS, MICROPHONES and LOUDSPEAKERS

Full details and prices from:

E.M.I. SALES & SERVICE LTD.

AMATEUR DIVISION

HEAD OFFICE, HAYES, MIDDX.



E194

WHAT IS THE I.S.W.L.?

- (1) The International Short Wave League is an organisation of short wave listeners, amateur transmitters, and others interested in short wave radio communication.
- (2) Its objects are to encourage, in every way possible, friendly intercourse and understanding between peoples of every country, through the medium of a common interest in their hobby.
- (3) Membership is open to anyone, of whatever race, creed, or colour, provided there is a genuine interest in short wave radio and a desire to further the aims of the League.
- (4) The membership fee consists of an annual subscription of 2s. 6d., or its equivalent. There is no entrance fee.
- (5) Contests, Set Listening Periods and Dedicatory Broadcasts are regularly arranged, in order to further the aims of the League.
- (6) Organisation consists of an HQ staff, Country, County and Town representatives, and local I.S.W.L. Groups. These latter are the essential units of I.S.W.L. activity, as they stimulate and keep together local I.S.W.L. members.
- (7) Many free services are available to help members to get the best out of their hobby. Amongst these is a QSL Bureau which is unique in that it handles both amateur and broadcast 'veries.'
- (8) A section of 'Short Wave News' is devoted each month to I.S.W.L. affairs, and carries news of contests and Group activities. The purchase of 'Short Wave News' is **NOT** a condition of membership.
- (9) The address of HQ is 57 Maida Vale, Paddington, London, W.9., and the telephone number is CUNningham 6518.

**IF YOU ARE A
SHORT WAVE ENTHUSIAST
—JOIN US NOW**

AN EASILY ADDED "S" METER

Centre Tap describes a Useful Accessory for addition to any Superhet Circuit fitted with AVC

FROM the time the superhet circuit first became popular, most of the better quality receivers have been fitted with some form of visual tuning indication. With the simple broadcast receiver some means of accurately determining the correct tuning point is a highly desirable feature. The superhet is inherently highly selective, and any deviation from the exact tuning point must result in a cutting of the side-bands, with a consequent deterioration in reproduction quality. It is far simpler to tune by the eye than it is by the ear, and receivers with any pretensions of being in the 'quality' class have always been fitted with one form or another of the various visual tuning devices, of which the magic eye has been the most popular.

The "S" meter, because of the greater ease in noting the optimum tuning point, is far more suited to laboratory work and communications receiver design, however out of place it may seem in the drawing room. Apart from this advantage, it is far more consistent with the "instrument" type cabinet than the "furniture" cabinet of the commercial broadcast receiver, and thus nearer to the hearts of the constructor and experimenter.

Simplest Application

With straight receivers, it was formerly customary for amateurs to include a milliammeter in the anode circuit of the detector valve and tune to maximum "dip" (the smallest meter reading). With a straight circuit such a device is rather by way of being a gadget, instead of a necessity as it is under the critical tuning conditions of a well-designed superhet.

It is of interest to note that in a circuit using anode bend detection the anode current, and therefore the meter reading, rises as a signal is accurately tuned.

A large number of the Services receivers have a switched position in order that the meter can be used as a tuning device (where no "S" meter is fitted) when in tuning the operator

can watch for maximum dip. In these receivers the meter is switched in series with one or more of the AVC controlled IF valves when a downward reading (fall in HT) in proportion to the strength of signal is obtained.

Such circuits too, were formerly popular amongst amateurs, who often fitted the meters upside down so that the needle movement was to the right. Indeed, at least one American firm manufactured a 'backward' reading meter especially for this purpose to enable it to be fitted the right way up!

Other Uses

Quite apart from the "S" meter's normal role of measuring signal intensity with reasonable accuracy, or at least of indicating comparative strengths, it serves as a first-rate guide to aerial performance and an invaluable asset in making alignment or other adjustments.

From the point of view of amateur communications radio, it is essential for enabling reliable relative reports on carrier strength to be made, or for measuring the back-to-front ratio of rotary beams, etc.

It must be remembered, too, that an S7 to 8 undermodulated signal may sound weaker than an S5 to 6 fully modulated signal. This should be particularly noted by SWLs who are interested in reporting and "veri" collecting. An inaccurate report is not only valueless but may be actually misleading.

Simple Circuit

An "S" meter on these lines was described in the Short Wave News for December, 1948, for addition to the Basic Superhet and similar receivers, the essential feature being that the set must incorporate an AVC system. It is, of course, the AVC which actuates the meter, its position in the circuit being the final IF amplifying valve.

It will not give readings for CW reception, although special arrangements can be made for this purpose. The AVC is always shorted

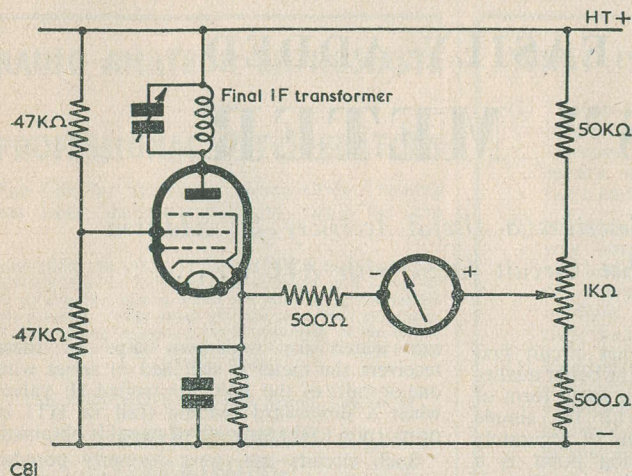

Fig. 1: Showing how the meter is connected.

out when the BFO is switched on.

The circuit shown is actually just as simple as it looks, both in wiring and in the initial adjustment. The resistor from the HT to the screen will, of course, be part of the existing circuit. That from the screen to the chassis will possibly have to be added and it should be of a value approximately equal to that on the HT side.

Operation

No current flows through the meter under "no signal" conditions, but, as the AVC voltage rises, current flows as the cathode becomes less positive and thus a forward reading is obtained. The resistor between the

meter negative terminal and the cathode is to prevent excessive current on very strong signals, and by increasing or decreasing its value the meter sensitivity can be varied. It should also be noted that it serves to prevent the bias from falling below its proper value, via the resistor on the positive side of the meter by which it would be shunted.

If it is found that the needle drives over hard against the back stop, either the value of the 500 ohm resistor from the potentiometer to the chassis should be reduced, or the value of the resistor from the potentiometer to HT positive should be increased. This applies to the normal operating condition—the needle will go over hard to full scale when the set is first switched on from cold.

The initial setting is made when the set has had time to warm up. The aerial lead is removed and the aerial terminal is shorted to chassis. The needle is then set to zero by the potentiometer adjustment.

Practical Considerations

The meter movement itself will depend on the receiver into which it is to be incorporated, and for one where it follows two RF stages a meter with a 3 or even a 5 mA movement could well be used.

A .05 or 1 mA moving coil instrument will be best for the average small receiver. The smaller the set the more sensitive the movement will need to be—it should never be necessary to need to improvise in order to get adequate readings.

In calibrating the scale it will be found to be far from linear—no "S" meters are! Nor is

it possible to lay down any arbitrary rules; much depends on the receiver efficiency. The reading is not only dependent on the relative incoming signals, but will also be affected by variations in the slope of different valves.

The scale will be cramped at the low reading end and a rough general approximation is given in the accompanying specimen. For the more technically minded it might be mentioned that a good working basis for the scale is a variation of 3 dB for each division.

Fitting

A convenient form of mounting where space is limited can be arranged with the assembly mounted on a paxolin or bakelite strip at the rear of the meter itself. The brackets supporting it are held by the meter terminals, and these may well also serve as soldering tags. If a midget pre-set type of potentiometer is used, this arrangement will occupy the minimum amount of space. The potentiometer, by the way, which is used for making the zero adjustment, must be a good quality one. The resistors other than the two forming the potential divider for the valve screen, can also be mounted on the platform.

An alternative arrangement with the meter forming a separate external unit, as in the Eddystone and some of the Hallicrafter models, may be preferred. In this case the associated resistors, etc. are best mounted in the separate unit and the three leads taken out via a plug and socket fitted at the rear of the receiver chassis. A miniature valve base and holder will be found ideal for this purpose.

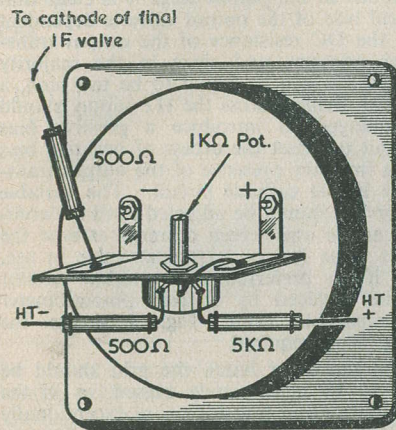

REAR VIEW OF METER SHOWING BRACKET ASSEMBLY

C82

GARLAND RADIO

AMPLIFIER ACIII: We are pleased to announce that we are now using a Varley Mains Transformer, specially wound for us, in this popular kit. Specification: 7 valves (incl. rectifier). Push-pull Output up to 10 watts (2 x 6V6G) to 3 or 15 Speaker (state which). Supply available for tuner unit &c. High and Low Gain Inputs. Separate Bass and Treble Controls. Partridge Output Transformer. Negative Feedback. Complete Kit, with circuits and instructions (incl. circuit of suitable quality local-station tuner) £7.10.0.

'OSMOR' GLASS DIAL ASSEMBLY: 3-colour, 3-wave, 7" x 7", with drive mechanism. 75/-.

I.F. TRANSFORMERS: 465kc, standard size, capacity tuned. Per pair 12/6.

T.R.F. COILS: M & L wave, with reaction winding. Per pair 6/6.

WEARITE 'P' COILS: Full range in stock. Each 3/-.

MAINS TRANSFORMERS: Pri. 0-200-220-240v. Secs. 270-0-270v 80mA. 0-4-6.3v. 4A. 0-4-5v 2A. Electrostatic screen. Tag connections. Universal mounting. Each 16/6.

MAINS TRANSFORMERS: Pri. 0-200-220-240v. Secs. 350-0-350v 80mA. 0-4-6.3v 4A. 0-4-5v 2A. Electrostatic screen. Tag connections. Universal mounting. A truly all-purpose transformer. Each 16/6.

BALANCED ARMATURE HEADPHONES: Type DLR2. With wide, comfortable double metal headband, lead and plug. The most sensitive low resistance phones made. Boxed. Per pair 5/-.

TRIMMERS: Miniature ceramic air-spaced 3-30pF. 6d. each, 5/6 per doz., £3 per doz. Philips Concentric type, 3-30pF. 7d. each, 6/- per doz., £3.6.0 per gross. Ceramic compression type 1000pF. 7d. each, 6/- doz.

ALADDIN COIL-FORMERS: Type F804, with iron dust cores. 5d. each, 4/6 per doz, 48/- per gross.

THERMALLY OPERATED MICROSWITCHES: Normally "on". Break at approx. 100°C. (adjustable). Control 10A 250v. Each 3/6.

OIL TEMPERATURE INDICATORS: A sensitive moving-coil movement, F.S.D. of which is approx. 120uA. Centre-tapped moving coil. Calibrated 0-120. Ideal as indicator in bridges, signal strength meter, valve-voltmeter movement, or can be modified as sensitive relay. 3/- each, 30/- per doz.

L.F. CHOKES: 15H, 40mA, 360Ω, 3/6 each. 20H 80mA tropicalised, each 3/6.

METER OFFER: 2 1/2" Meters, FSD 50uA D.C. Few only at 32/6 each.

STABILIZERS: Type NS1. Voltage stabiliser and divider. Operating voltages 280v, 210v, 140v, 70v. Max. electrode current 80mA. Each 10/-.

TOGGLE SWITCHES: D.P.D.T. Black bakelite, 2/6 each, 27/- per doz.

AERIAL RODS: Heavily copper-plated steel, one foot long. Fit into one another to make any length aerial. Per doz. 2/-.

METERS: 2 1/2" 0-150v A.C. American, with provision for illumination of dial, each 6/6. 2" 0-50mA D.C. 6/-.

PLUGS AND SOCKETS: Pye angle 1/6; Pye Straight 1/3; B & L 5pin 1/6; B & L 7pin 1/9; B & L 10 pin, 2/-; Jones 6 way 1/6; Jones 8 way 1/9; Jones 10 way 2/-; Jones 12 way 2/6; E.H.T. Single 1/6. The above prices include plug and socket in all cases. Jack plug with Igran socket 2/6. Pye T-pieces 6d. Pye Connectors 6d.

CLEARX VISION ENLARGERS: The magnifying lenses that do not discolour. 9" £2.10.0; 9" with built-in filter £2.15.0.

SELENIUM RECTIFIERS: 280v 300mA Half-Wave 10/- each. 24v 1.2A Bridge, 12/6 each.

OVERLOAD CUT-OUTS: Adjustable from 50 to 100mA. Ex-equipment. 4/- each.

MICA TX CONDENSERS: 500pF, 1.5A at 4 to 7.5 Mcs. Test 5000v A.C. for 10 minutes. 6 for 5/-.

GARLAND BROS., (Dept. R.C.)

Chesham House, Deptford Broadway,

London S.E.8.

Telephone: TIDeway 4412/3.

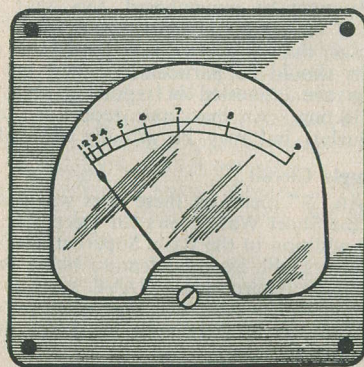

FRONT VIEW OF METER

C83

A CATHODE FOLLOWER OUTPUT STAGE

by D. W. DRAKELEY

AN appreciation of the virtues of the Cathode Follower as a means of feeding a low impedance load from a high impedance signal source suggested experiments to determine the possibilities of the system when used to feed a loudspeaker load from a normal pentode or tetrode output valve.

The experiment was carried out on a five valve superheterodyne of otherwise conventional design and the output stage was first arranged as shown in Fig. 1., which shows that the output voltage is developed as usual in the primary winding of the output transformer, which for this purpose however replaces the normal bias resistor and capacitor, between the cathode of the output valve and earth, the anode and screen of the valve being returned direct to the HT line, so that the valve functions effectively as a triode. The voltage developed across the output transformer is thus in series with, but in opposition to, the incoming signal voltage across the grid load impedance R; thus providing an extreme case of negative feedback in which the whole of the output voltage is fed back, instead of only a small fraction as in the usual negative feedback arrangements.

One of the less desirable effects of this high degree of degeneration is, of course, to reduce the overall sensitivity of the stage very considerably, and its gain is in fact reduced to rather less than unity. Although all forms of distortion are of course reduced in the same proportion as the gain, we are nevertheless faced with the problem of obtaining from the preceding stage a volume of signal sufficient to balance out the whole of the output voltage which is being fed back in opposition to it, and at the same time to provide the additional voltage required to load fully the output valve.

This difficulty can be overcome to a limited extent by the selection of an output valve of

high sensitivity, such as the Osram KT61, but even so, in the writer's superhet, using resistance-capacitance coupling, it was found to be impossible to load the output valve fully, without introducing a further stage of AF application between the double-diode-triode and the output valve. This was impracticable for reasons of space and it was therefore decided to introduce transformer coupling parallel-fed between these two valves as a means of increasing the overall gain. An ex-Govt. mumetal cored transformer of 5:1 ratio was obtained quite cheaply and was found to introduce little noticeable distortion over the transmitted band of frequencies whilst providing the additional inter-stage gain required. These arrangements are shown in Fig. 2.

From an examination of the DC circuit conditions in the output stage it is clear that the grid bias of the output valve is dependent upon the DC resistance of the output transformer primary, and since in the majority of cases this will be found to be too high, a potential divider across the HT supply should be employed to introduce a positive bias sufficient to offset the excess of negative bias arising from the presence of the output transformer in the cathode circuit. The variable resistor VR should be adjusted until the combined anode and screen currents assume the correct value for the particular valve in use, when if so preferred the variable resistor may be replaced by a fixed potentiometer of comparable value. Fig. 3 shows the arrangement required.

If on the other hand, the grid should be found to be inadequately biased, as in the case of an output transformer of exceptionally low DC resistance, the position may of course be remedied by the insertion in the cathode circuit of the necessary additional resistance R_K by-passed in the usual way by a 25 μF capacitor, as in Fig. 4.

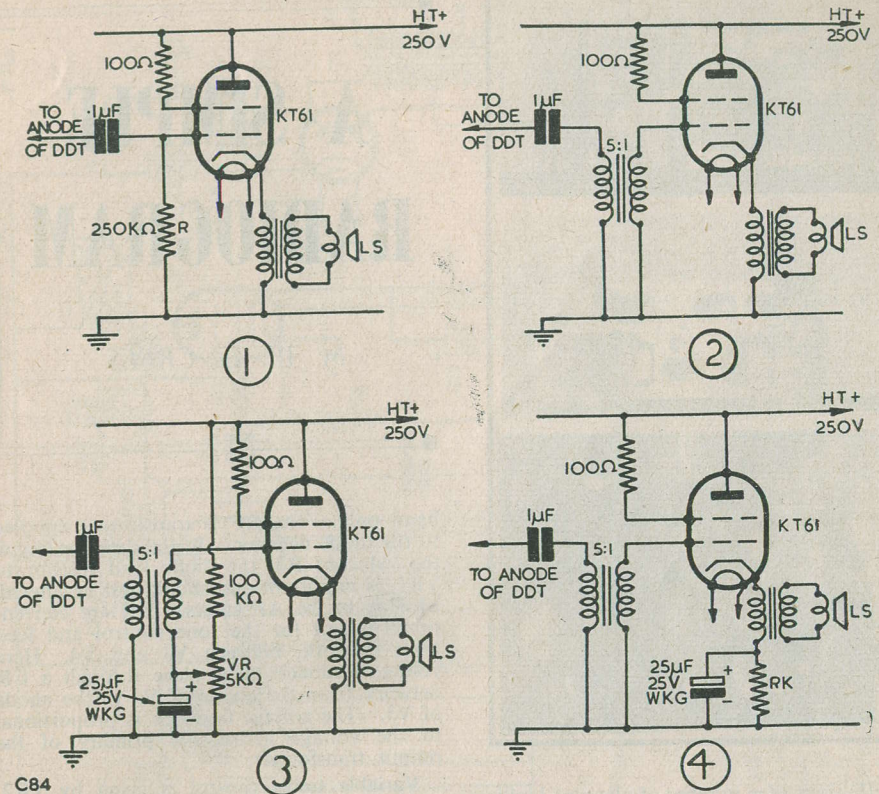

Fig. 1: The basic arrangement. This had to be modified as in Fig. 2., in order to avoid lack of sensitivity.

Fig. 2: Increased gain obtained by substituting a transformer for the resistance-capacitance coupling of Fig. 1.

Fig. 3: Modification of Fig. 2, to provide for the adjustment of the grid bias to the correct figure, where the bias voltage is found to be excessive.

Fig. 4: Modification of Fig. 2, to provide for the adjustment of the grid bias to the correct figure, where the bias voltage is found to be inadequate.

The quality of reproduction compares very favourably with that of even a first quality commercial receiver, and due to the heavy damping of the loudspeaker by the extremely low output impedance of the stage, the response to transients is quite noticeably improved. This is most marked in the reproduction of

piano music. The bass response is pleasantly even and free from "thumps", due to the heavy damping of speaker resonances. As a result of the large degree of feedback, the results are probably the best that can be obtained from any single valve arrangement from the viewpoint of quality and absence of distortion.

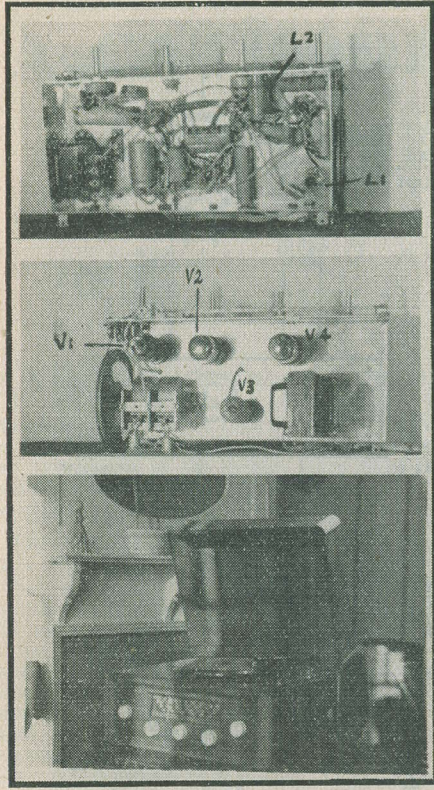

A SIMPLE RADIOGRAM

by W. E. CREES

band only. The RF is transformer coupled to the diode detector. In the detector circuit the value of R3, the diode load resistor to VR1, is important and should not be altered. Moving to the AF stages, these are conventional except for the tone control and feed back network, between V3 and V4. Here voltage feedback takes place through a CR network from the anode of V4 to the anode of V3. The voltage feedback is proportional to the voltage across the primary of the output transformer.

Variable treble control is given by VR2, while C17 gives a fixed bass boost. This circuit is very useful as a means of minimising the scratch on old records. The power supply is built on a small separate chassis partly because of space limitations, but chiefly to help remove as far as possible the mains transformer from the vicinity of the high gain AF stage and away from the gram, pick-up. If a shallow cabinet is used, as in the author's case, a problem immediately presents itself. The depth between the motor board and the bottom of the cabinet is insufficient for a large speaker. This was solved by using two 5 inch speakers in parallel. Readers will be aware of the advantages of using a large speaker with a good baffle area, but in spite of not being able to do this, there is no noticeable deterioration in quality. Also overloading of the speaker does not take place. If a large cabinet is to be used, then twin speakers will not be necessary. The use of two speakers in this way means they must be

THE sight of a number of pleasant looking table model gram. cabinets in one of London's well known radio shops resulted in the construction of the radiogram to be described. Although this was built for use with the above mentioned cabinet, the reader will quite easily be able to adapt the circuit for use with his own ideas on the housing of the finished model.

The circuit consists of a TRF for MW only, using EF39 for RF and 6H6 as detector, feeding into an EF37 AF stage with 6V6 output. The output incorporates tone control and negative feed back. All components are easily obtainable, and the results very satisfactory. The EF37 is capable of giving all the gain from the PU that is necessary to drive the output stage.

A TRF was chosen, because of one, its simplicity, and two, its high quality, to which the AF stages can do justice. A pair of Wearite PA2 coils are used to cover the MW

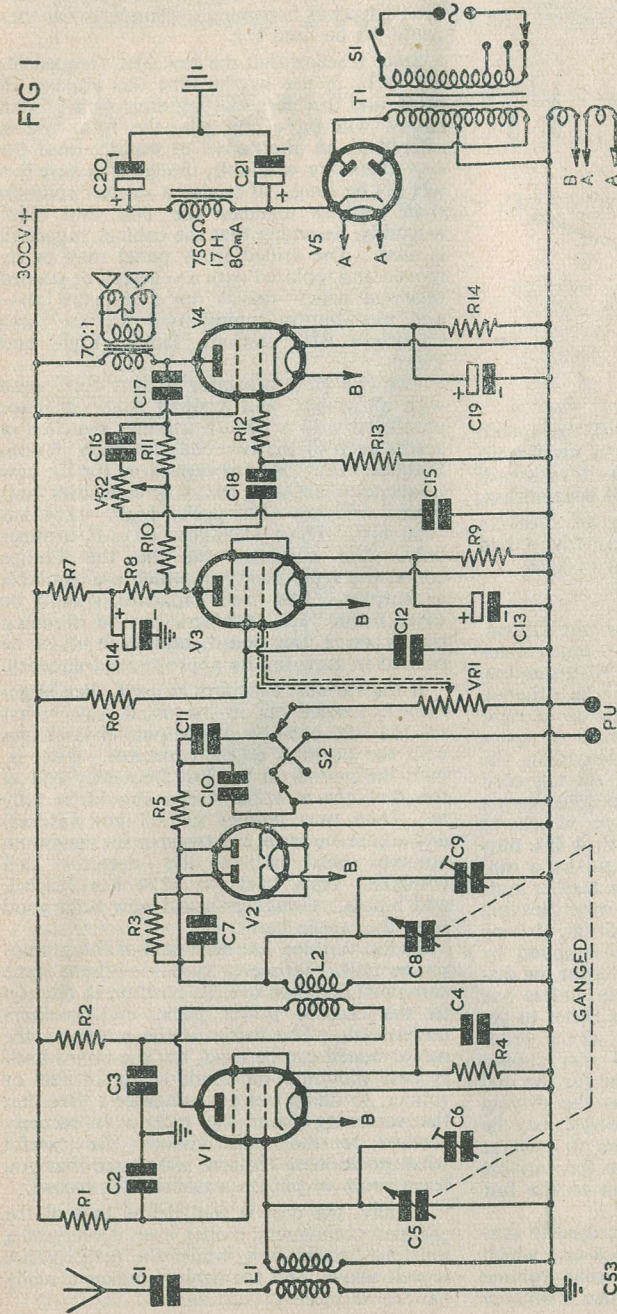
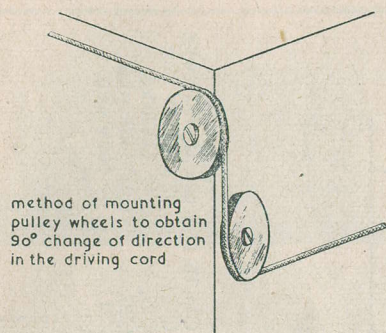

Fig. 1: Theoretical circuit of the simple radiogram.

VALUES OF COMPONENTS

- R1, 82k Ω
- R2, 7, 10 k Ω
- R3, 250 k Ω
- R4, 330 Ω
- R5, 50 k Ω
- R6, 390 k Ω
- R8, 220 k Ω
- R9, 3.3 k Ω
- R10, 1 Meg Ω
- R13, 700 k Ω
- R14, 240 Ω
- All resistors ½ W except R1, 2, 14 ¼ W
- VR1, 2, 1 Meg Ω
- L1, Wearite PA2
- L2, Wearite PHF2
- T1, 350-0-350V @ 80/100 mA.
- C1, 240 Ω
- C2, 10 k Ω
- C3, 250 k Ω
- C4, 330 Ω
- C5, 50 k Ω
- C6, 390 k Ω
- C7, 220 k Ω
- C8, 3.3 k Ω
- C9, 1 Meg Ω
- C10, 700 k Ω
- C11, 240 Ω
- C12, 10 k Ω
- C13, 250 k Ω
- C14, 330 Ω
- C15, 50 k Ω
- C16, 390 k Ω
- C17, 220 k Ω
- C18, 3.3 k Ω
- C19, 1 Meg Ω
- C20, 700 k Ω
- C21, 240 Ω
- C22, 10 k Ω
- V1, EF39
- V2, 6H6
- V3, EF37
- V4, 6V6
- V5, 5Z4
- S1, SPDT toggle
- S2, DPDT midget type
- C15, 16, 17, 0.001 μF 350V wkg.
- C18, 0.02 μF 350V wkg.
- C19, 50 μF 12V wkg.
- C20, 16 μF 500V wkg.
- C21, 8 μF 500V wkg.
- V1, EF39
- V2, 6H6
- V3, EF37
- V4, 6V6
- V5, 5Z4



method of mounting pulley wheels to obtain 90° change of direction in the driving cord

Fig. 2

C54

matched to the output valve. If the speech coil is the usual 3 ohms, then a multi-ratio output transformer giving a 70—1 ratio will do the trick, and the mis-match is insignificant.

A number of different types of speakers were tried. The best the writer found had a really large, square permanent magnet.

Construction

The layout of components is not critical, though it is advisable to allow as much space between V3 and V4 as possible. All grounding should be done with care. In the original, the twin gang capacitor is mounted at right angles to the dial, again because of space limitations. The method of obtaining the 90° change of direction in the driving cord to do this is shown in the accompanying drawing. The small pulley type wheels to carry the cord are mounted with 4 BA nuts and bolts. The bolt is held rigid by a nut, then the wheel is put on, two further nuts are used to lock one against the other, leaving the wheel free to turn. The drum, driving spindle, pointer and dial were supplied by Premier Radio. It is necessary to cut the dial leaving only the MW band, but unless one is handy with a glass cutter it is better to get a local tradesman to do the job, as the writer knows to his cost. This dial was chosen because it is of just the right size for the dial opening in the cabinet. Unless the driving drum and dial are matched, trouble may be experienced in getting the pointer to traverse the full length of the dial, while the variable capacitor goes from the fully in to the full out position.

A separate on—off switch was used to prevent any tendency to hum pick-up, which sometimes happens with the usual volume control/on-off combination. Also, because

the cabinet was drilled for five controls and the writer was beginning to wonder what they could all be used for.

Since it seems that the new BBC frequencies are to be in use by the time this appears in print, and therefore existing dials with printed names will be of no use, the following is offered as an alternative to waiting until the new dials are available, though I'm sure this will not be long. It is also a simpler solution than putting together the dial and drive assembly, assuming that the cabinet suggested is used. The drilled front panel may be removed and replaced with a veneered or stained plywood panel—this is not a difficult job—and push-button tuning used for the three important BBC stations, Home, Light and Third.

The two gang capacitor is then done away with altogether, and a small fixed capacitor paralleled with a 60 $\mu\mu\text{F}$ trimmer switched in across each of the two coils for each station. Suitable values of fixed capacitors for the new frequencies, allowing for stray capacities, are: Home, 908 kcs—120 $\mu\mu\text{F}$. Light, 1214 kcs—50 $\mu\mu\text{F}$. Third, 1546 kcs—60 $\mu\mu\text{F}$, trimmer only. The trimmers can be the Philips concentric type, plenty of which are available as surplus. The fixed capacitor should be silver mica. The trimmers can be mounted rigidly on a tag board, and each must be peaked in turn for its appropriate frequency.

If the variable capacitor is used, then alignment is carried out in the usual way. First see that the position of the pointer coincides with the position of the capacitor. That is, with the pointer at the low frequency end of the dial, the movable vanes should be fully in. Then turn pointer to 908 kcs. (Home) and adjust the aerial coil trimmer for maximum volume. Next adjust the detector coil trimmer. Turn back to 1214 kcs (Light), and repeat. Ganging should now hold good over the whole band.

So far, nothing has been said of the gramophone unit. Whatever type is chosen, some care must be taken over its position in relation to the chassis, power pack, and speakers underneath. The fixing of the motor to the motor board can be rigid, but the board itself is best mounted on small strips of felt or rubber, to damp out any vibration. See that the screening from the pickup is securely earthed to the main chassis. Be careful when positioning the arm rest to see that you leave room to put on a twelve inch record.

Finally, the cost is well below that of the cheapest commercial model, even if everything must be bought new, whilst the performance is well above, and the cabinet makes a really handsome piece of furniture.

Building Your Own Signal Generator

A NEW ATTENUATOR

by W. G. MORLEY

The writer is indebted to W. E. Thompson (St. Leonards-on-Sea) for pointing out several discrepancies in the attenuator circuit shown on Page 185 of the February issue of the *Radio Constructor*; and has therefore designed a new attenuator which may be used instead of the one originally published and which showed incorrect values of resistance in one of the arms.

This new attenuator circuit is shown in the accompanying diagram. It may be seen that the coarse attenuator switch offers outputs of "Full", 1/10, 1/100 and 1/1000 of the voltage obtained from the oscillator. These voltages are again split up by the fine attenuator, which gives ratios of "Full", 0.8, 0.6, 0.4, 0.2 and 0.1 of the output given by the coarse attenuator.

The impedance presented at the input to the attenuator is approximately 100 Ω , whilst that at the output varies between 0.1 Ω and 100 Ω . On the "Full" position of the coarse attenuator, the left-hand potentiometer network is switched out of circuit, the fine attenuator itself then providing the input impedance.

If the ratios given by this circuit are calculated it will be found that those offered by the coarse potentiometer are actually 1/10.08, 1/102 and 1/1011, and not the exact figures mentioned above. The slight discrepancies are due to the fact that, except in the "Full" position of the coarse potentiometer, the 100 Ω of the fine potentiometer network is in parallel with whatever part of the coarse potentiometer falls between the coarse tap and the common chassis connection. The values of the coarse potentiometer have been chosen to allow for this; and also to enable sufficiently useful ratios to be obtained without incurring the use of awkwardly valued resistors.

In addition, the slight alterations caused by connecting the fine potentiometer across the various sections of the coarse network cause some slight changes in input impedance. This varies between 99.91 Ω and 101 Ω . This variation is, of course, too small to cause any noticeable changes in oscillator characteristics.

There is also a small error in the frequency given for the PA 6 coil on page 153 of the

January issue. For 50 pF capacitance, this coil should resonate at 3,680 kcs and not 3,280 kcs. The error was caused by an error in typing from the original manuscript.

W. E. Thompson, who has used "P" coils in his instrument, passes on some interesting information about the signal generator; stating, amongst other things, that the cathode follower circuit of page 182 of the February issue has cleared up a lot of trouble in his particular model. He also states that he has extended the range of the PA1 coil to just below 110 kcs by switching in an extra 500 pF capacitor across the tuned circuit, thus enabling old-fashioned receivers which employ that IF to be serviced.

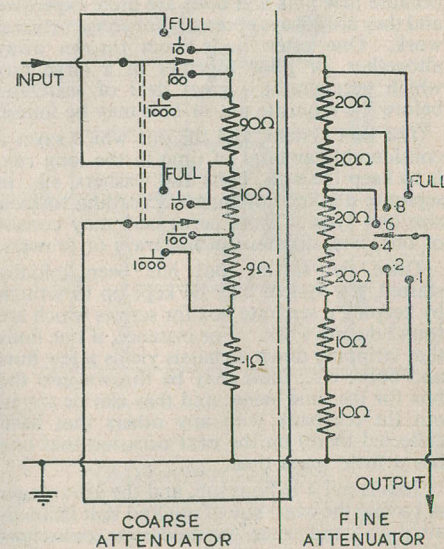

C129

YOUR WORKSHOP

In which J. R. D. Discusses Problems and Points of Interest connected with The Workshop side of our Hobby, based on Letters from Readers and his own Experiences.

Junk!

It is certainly worth while keeping all the useful stuff, but the rest should really be thrown away. With regard to components, these should be kept only if they are serviceable and are not of obsolete patterns. Broken down capacitors and burnt out resistors should of course be thrown away at once, in case one should accidentally try to use them again. Components which may be stripped can have their useful parts removed before being discarded. For instance, burnt out transformers can yield some useful nuts and bolts (and the laminations, if required) before they are finally thrown away. Or again, old volume controls possess bushes and mounting nuts, etc., which are worth while keeping.

Nuts and bolts, particularly small ones, are items that seem to suffer most in the average workshop. This is difficult to understand because new nuts and bolts are quite expensive and they are always necessary for constructional work. One often finds them thrown away altogether, or piled together in a large box which necessitates a great deal of searching before the requisite nut or bolt may be found.

The best system, and the one which saves a considerable amount of time in the long run, is to keep the nuts, bolts and washers, etc., in separate marked containers according to their size and type. These containers may consist of tins, jars, divisions in flat trays or drawers.

Once the sorting out has been initially started, the system may be kept up to scratch by keeping a separate box for screws which are found during work. For instance, if one finds that stripping down a chassis yields a few nuts and bolts, etc., these may be thrown into the box for the time being; and they can be sorted out (in company with any others that have collected there) on the next occasion that one has a little spare time.

This is not a tedious job, and the advantages of having the exact size of nut and bolt immediately on hand when required soon outweighs the small amount of time spent in keeping them sorted out.

The Workshop as a Whole

Perhaps the most important attributes are comfort, accessibility of equipment and plenty of space to move about in.

Comfort is very important, as one may spend many hours in the workshop, and it is easy to become overtired if little points which make things easier are not attended to. Such things as good lighting, fresh air, warmth and so on, all help in this direction.

The work bench itself is also important owing to the large amount of time spent at it. The best bench is one at which it is possible to work comfortably either standing or sitting. This can be ensured by having the bench about three feet from floor level and using a fairly high chair or stool for those jobs which allow one to sit down. The underneath of the bench should be kept free from boxes, etc., so that there is plenty of space for the knees.

Accessibility of equipment consists mainly of the careful planning of bench and shelf dimensions and of their positions. Plenty of workshop space is not always easily obtainable, but cramped quarters can be made to give a fair amount of room if the layout of the workshop is given careful consideration when it is originally planned.

Many amateurs also like to give their workshops something of the atmosphere of a "den", as this not only helps to give the room a comfortable air, but also enables them to invite their friends in to relax in congenial surroundings.

★ SHORT WAVE NEWS

We regret that, owing to the present dispute in the printing trade in the London area, it is impossible for us to give precise information as to the date of appearance of our companion journal "Short Wave News". Readers may rest assured that it will be produced as soon as circumstances permit.

"from our MAILBAG"

Valve Tester

Dear Sir,—Referring to the current article "Building Your Own Valve Tester", may I make a suggestion which would appear to have some practical value.

If the 6X5 rectifier in Fig. 3 is replaced by a metal rectifier of suitable rating, one can at once omit R6 and the 6.3V heater winding. Moreover, since this metal rectifier will deliver grid bias potential almost immediately the tester is switched on, it automatically ensures that the valve under test has full grid bias before HT is applied. One can therefore use any type of rectifier for HT; the 5Z4 specified to guard against HT being applied before GB can therefore be a similar directly heated type, or even a full-wave metal rectifier.

Incidentally, and as a matter of interest, the following observations might give others some food for thought. In the circuits of Figs. 2 and 3 we have a full-wave rectifier for HT (Fig. 2) and a half-wave for GB (Fig. 3). The HT rectifier conducts twice each cycle whereas the GB rectifier conducts but once. What effect will this feature have upon the grid bias and anode current of the valve under test, and the consequent mutual conductance reading obtained?—

W. E. Thompson (St. Leonards-on-Sea).

(Mr. Thompson is quite correct in stating that a metal rectifier can be used to replace the 6 X 5 of Fig. 3; and as this will supply grid bias as soon as the tester is switched on, there will then be no necessity to have an indirectly-heated valve as HT rectifier. The point of omitting the 6.3 volt winding will not apply in most cases, as the type of transformer used would almost inevitably be fitted with such a winding. In addition, the use of a metal rectifier might perhaps prove an advantage, insofar as it would reduce the initial cost of the tester.

The fact that a full-wave rectifier for HT and a half-wave rectifier for GB are employed will not affect the mutual conductance readings at all, as the tests are all carried out with stabilised DC. The outputs of the rectifiers, whether full or half-wave, are all smoothed before being applied to the valve under test.

It must, of course, be pointed out here that the constructor does not necessarily have to use the power supply circuits given in Figs. 2 and 3, although these should provide the best means of

obtaining the various voltages required for the tests. If he has other components available which are capable of supplying the requisite currents and voltages to the stabilisers, then these can be used. However, care must be taken to see that such a supply is adequate and well-smoothed, and that all other requirements mentioned in the articles are satisfied.—

W. G. MORLEY.

Inexpensive Televisor

Dear Sir,—I have made the set more or less per the book, and find my three main faults are (1) Background noise from RF26 Unit causing grain on the picture (I am 67 miles from SC) (2) IF break-through and (3) Slight non-linearity at top end of frame.

Only to-day, though, I have reduced fault No. 3 by the addition to frame amplifier shown in the diagram. I hope this may be of interest to you.—T. Walker (Runcorn, Ches.).

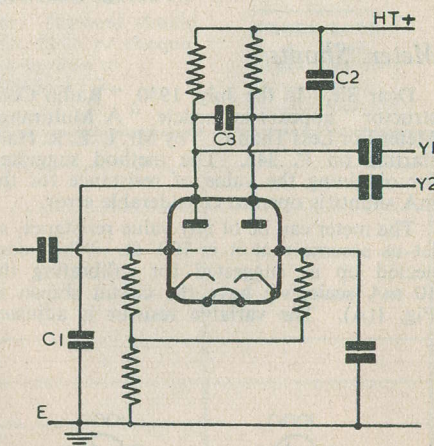

MBI

COMPONENT VALUES

C1, 0.001 μ F C2, 0.01 μ F C3, 0.001 μ F. These values may need adjusting in some cases, and C1 and C2 connection (HT + or E) may need to be changed.

Mains/Battery Receiver

Dear Sir,—I was agreeably surprised to read the replies concerning the trouble I was having with my receiver, and which you so kindly sent along to me. It really is very pleasant to have a hobby in which one's fellow-enthusiasts are only too pleased to give their spare time in helping one over awkward snags; and I should like to express my thanks to all the readers who wrote to help me.

The particular fault I wrote about has now been cleared by replacing the electrolytic capacitor connected across the filaments, the one previously fitted having apparently become open-circuit. I am now beginning to realise that it was the added AC which caused the heaters to glow more brightly, while it didn't affect the DC meters. At any rate, I haven't burnt out any more valves!

Before concluding I should like to state that I have been a reader of the "Constructor" for several years now and it has helped considerably in increasing my knowledge of the hobby. Particularly instructive and interesting were the articles on "The Design of the Superhet" and the "Logical Fault-Finding" series; the latter having helped me a great deal in repairing my own and friends' receivers.—

W. Savage (Kilburn).

Meter Shunts

Dear Sir,—In the July, 1950, "Radio Constructor" appears an article "A Multirange Meter For Less Than £3" by Mr. L. E. R. Hall, starting on P. 345. The method suggested for obtaining the value of resistance for the mA shunts is open to considerable error.

The meter can be of any value resistance, so let us assume that it is 100 Ω. When connected up as suggested for calibrating the 10 mA scale, we have the circuit shown in Fig. 1(A). The variable resistor is adjusted

for full-scale deflection (1 mA). Now we shunt the meter with a resistance which we vary until the meter shows a deflection of one-tenth full scale. This gives the circuit shown in Fig. 1(B).

The shunt resistance will be somewhere about 11 Ω and so the total resistance of the meter and parallel shunt will now be approximately 10 Ω. Now we have NOT moved the variable resistor, but due to the total resistance in the circuit being lower than before, the current in the circuit has increased, i.e.,

$$I = \frac{E}{R} = \frac{1.5}{1410} = 0.00106A \text{ or } 1.06 \text{ mA.}$$

This error is on the 10 mA scale. On the higher ranges the error will be greater, as the shunt will be of lower value and so the total resistance will be smaller and the current greater, in addition to which there is the error on the previous range.

These errors must be allowed for by calculation, or eliminated altogether by using a milliammeter of known accuracy in series with the variable resistor and meter under calibration, to show that the current flowing is indeed 1 mA, 10 mA, etc., etc.—

R. Jones (Bromley, Kent).

(Mr. Jones is quite correct, of course. We suggest that the procedure described is quite satisfactory if, when the shunt is being adjusted, a resistor be inserted in series with the variable, having a value approximately equal to the loss in total resistance, which may be calculated using $1/R = 1/R_1 + 1/R_2$ to find the effective resistance of the meter and parallel shunt. The result will be well within the accuracy with which the ordinary meter scale can be read.—Ed.)

BRENTFORD EVENING INSTITUTE

Two technical radio courses are being held this season, the first of these being a radio servicing course which is a course of general radio interest without radio examination under the tutorship of Mr. J. A. Gibbons of the E.M.I. Organisation. Classes—every Tuesday 7 to 9 p.m. commencing September 19th and continuing for 6 months. Fee for complete course 10/-.

Second course is a Radio Amateur's course aimed at fitting students for the City and Guilds examination to be held in May, 1951, and is under the Tutorship of Mr. E. J. Pearcey, G2JU, of the E.M.I. Organisation. Fee for the course 10/-, excluding City and Guilds fee. Although the courses have started, students may still enroll. Apply to Mr. G. V. Mills, Principal, Brentford Evening Institute, Boston Manor Road, Brentford.

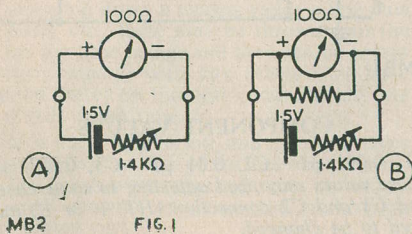

Inexpensive Television

The fourth in our popular Data Book Series, this publication describes the construction of television receivers from ex-Govt. surplus equipment, which is cheap and easily obtainable. This book was published in its original form some twelve months ago, and sold 40,000 copies. With its aid, televisions were built which operated far outside the normal service areas, and in all parts of the country.

The new edition, which is double the size, gives a much wider choice of equipment suitable for conversion, and will be equally popular with all television constructors.

PRICE 2/6 (post 2d.)

from your local supplier or direct from

AMALGAMATED SHORT WAVE PRESS LTD.

57 Maida Vale, Paddington, London W.9

Phone: CUN. 6518

METAL WORK with a difference!

If you want a well-made, attractive and robust cabinet for that receiver or transmitter; if you need a chassis for a modulator, amplifier or converter; in fact, if you need any metalwork at all for your ham requirements

YOU CAN DO NO BETTER THAN TO WRITE US FOR AN ESTIMATE

All metal work "made to measure"

For full details and address of nearest agent, contact—

L. J. PHILPOTT (G4BI)

(E. J. PHILPOTT)

Chapman St., Loughborough

Telephone: 2864

USE THIS FORM FOR SMALL ADVERTISEMENTS

PRIVATE RATE PER WORD Minimum 2/-

Terms cash with order. Payment should be made either by P.O., M.O. or cheque, crossed and made payable to ALDRIDGE PRESS LTD.

TRADE RATE PER WORD Minimum 6/-

To the Advertisement Manager 'Radio Constructor', Aldridge Press Ltd. 15 Charterhouse Street, London, E.C.1

Please insert this advertisement under the heading.....for.....insertions I enclose remittance.....s.....d. If Box No. required?.....!/- extra)

NAME.....

ADDRESS.....

USE BLOCK LETTERS

SMALL ADVERTISEMENTS

Readers' small advertisements will be accepted at 2d. per word, minimum charge 2/-. Trade advertisements will be accepted at 6d. per word, minimum charge 6/-. If a Box Number is required, an additional charge of 1/- will be made. Terms: Cash with order. All copy must be in hand by the 10th of the month for insertion in the following month's issue.

PRIVATE

WANTED. "Radio Constructor" Vol. one No.'s one to five inclusive. Also Vol. three No.'s five, ten and eleven. Please state price.—G. Gregory, 24, Caversham Road, Reading, Berks.

BLACK CRACKLE paint. Beautiful finish. Stove or air-dried. Enough for ten square feet, two shillings post free. Satisfaction guaranteed.—Geoff. Wheatley, G8QB, 80, Millmead Road, Margate.

R.F. SIGNAL GENERATOR type 1130A 100—150 megacycles xtal/M.O., 5.0/P steps, O/P control, O/P meter and leads. No charts or gen., but 10 xtals, copper cabinet. Less power pack. What offers?—Box No. A127.

AVOMETER model 40 £10 or exchange for R1155 with power pack. R1355 with RF25, valves £3.—Holden, 450, Burnley Road, Waterfoot, Lincs.

UHF RECEIVER type R1334 AC mains. 90—210 mc/s. Six RF heads. 27 valves. Offers—Box No. A128.

FOR SALE. Television, homebuilt from Premier kit. Completely assembled except for aligning. Must sell due to going abroad. Price £15 includes CRT(VCR 97), "V" aerial, 40ft coaxial. Write for appointment.—F. Brandis, 76 Woodlands, N.W.11.

SERVICE VALVE TESTER type 4A, requires slight adjustment £5 10s. 0d. New receiver chassis type 38, part of DF/Type 5070. Ideal for experimenters, £4 0s. 0d.—Box No. A130.

WANTED. Radio Constructor Vols. 1 and 2. Vol. 3, Nos. 1 to 7.—Dowson, 4, Melrose Street, Scarborough.

FOR QUICK SALE. Part modified 1196 receiver all necessary components, circuits. Ferranti test meter, headphones and miscellaneous components £9. 0. 0. lot. Owner selling up. Box No. A131.

FOR SALE 1155N. As new. Offers to 36, Sandy Lane, Teddington, Middlesex.

FOR SALE. R107 perfect condition, first class reception £10. H.R.O. coil packs, 20/- each. 1132 receiver, brand new £2.—Mansfield, 8, Terrace Walk, Dagenham, Essex.

TRADE

G6MN for the "best" QSL's and approved log books, send for samples: G6MN, Bridge Street, Worksop, Notts.

COMPONENTS. Eddystone, T.C.C., N.S.F., etc. Order from Smith, 98, West End Road, Morecambe. Send for lists or quotations.

ABSOLUTELY NEW. Ex-Govt. Valves. 5Z4, 6V6, 6X5, 6K7G, 6K7GT, 6V6GT, 6J7, EBC33, DDL4 (VR119), 6B8, 6AG7, 9D2, 6AC7, 6SK7, 6N7, 6SG7, KT44, all 5/9d. 807, 6Q7, EF39, 5U4G, 6F6G, all 6/3d. 6SH7, VU111, 635, all 4/6d. 77, 78, 25A6G, 12K8, OZ4, 42, 80, 7Q7, 6C6, 6D6, 1S4, 1R5, 3S4, 1S5, 1T4 PEN 46 all at 7/-. Carriage paid over 15/-. Alpha Radio Supply Co., 5/6 Vince's Chambers, Victoria Square, Leeds, 1.

QSLs and G.P.O. approved log books. Samples free Atkinson Bros., Printers, Elland, Yorks.

A PORTABLE TELEVISOR. The first-ever Portable Televisor designed for the home constructor is described and illustrated very fully in our 56 pp. book 3/2 post paid, which shows how only 14 valves (sound and vision complete) operate either a 3in. or 6in. tube for either TV area. A new, thoroughly tested circuit, which can be built up in a remarkably small carrying case. "Personal Portables", our first book, is more popular than ever. It gives full details for building 5 midget loudspeaker personal sets, T.R.F. and superhet; great value at 2/8 post paid. Both from BRADBROOKS, Sennen, Penzance, Cornwall.

MIDGET SPEAKERS ideal for personal portables, 2½ ins. P.M. M.C. 3—5 ohm voice coil, 6/- each, 15/- for 3. Terms Cash with order.—Pearce, 93, Canning Road, Wealdstone, Harrow, Middlesex.

ADCOLA

(Regd. Trade Mark)

SOLDERING INSTRUMENTS



Reg. Design No. 860302
(British, U.S. and Foreign Patents)

Designed for wireless assembly and maintenance. Supplied for all volt ranges from 6/7v to 230/250v. High Temperature, Quick Heating, Low Consumption, Light Weight.
3/16" Dia. Bit Standard Model 22/6
1/4" Dia. Bit Standard Model 25/0
3/16" Dia. Detachable Bit Type 30/0

Sole Manufacturers: **ADCOLA PRODUCTS LTD.**
Registered Offices:—

Alliance House, Caxton Street, S.W.1 (MAC. 4272)

THE BASIC SUPERHET

This book describes the construction of a simple superhet receiver. "Centre Tap" also describes suitable extensions, such as Adding an RF Stage, A Preselector, and a BFO, by means of which the performance can be enhanced to approaching that of a communications type receiver. Coil Data is included. Price 1/-. Postage 2d.

Amalgamated Short Wave Press Ltd.

57 Maida Vale, Paddington,
London — W.9

Telephone: CUNningham 6518

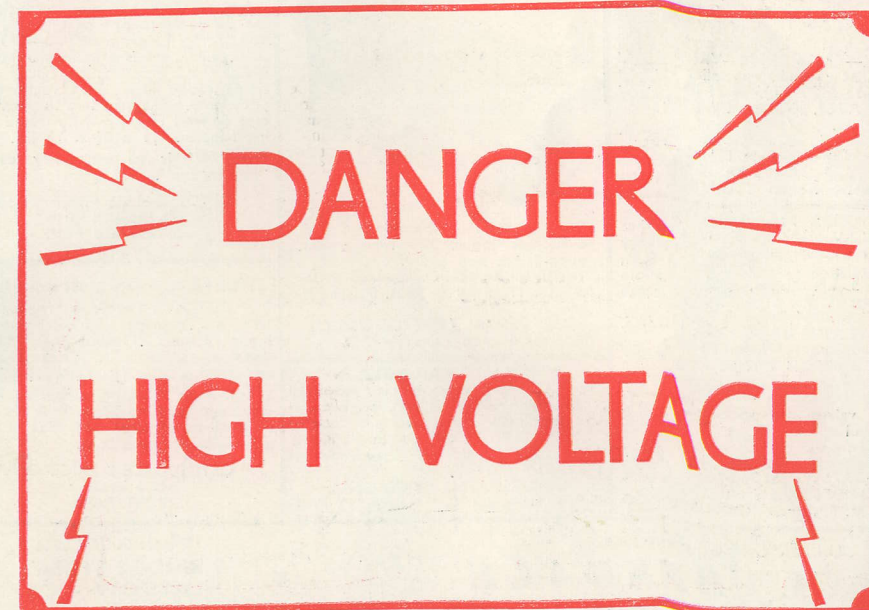
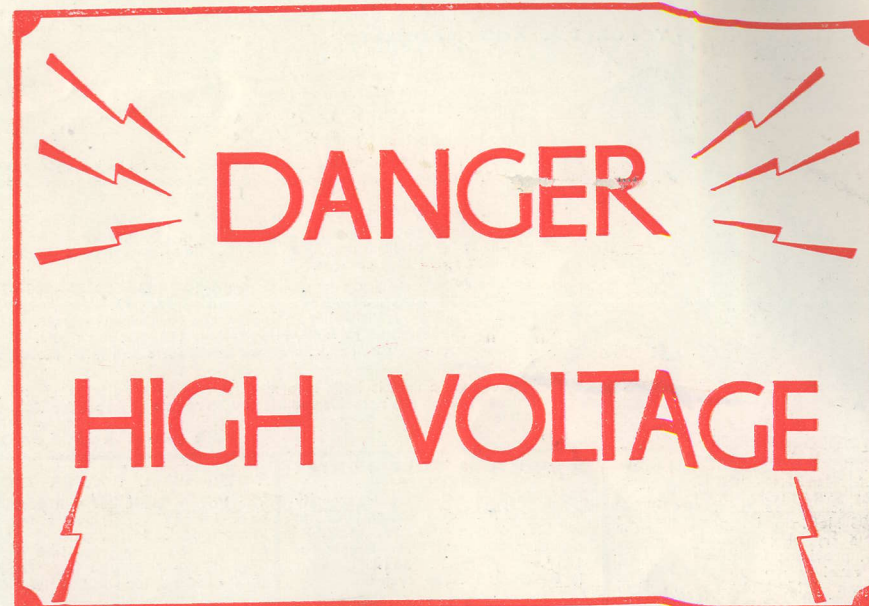

Panel Sheet No. 5.

Cut out and paste on to panel. Protect with Sellotape or clear nail varnish.